



SHIPLAP PANEL

System Technology for Facades

For up-to-date information, technical reports, advanced technical information, parts lists, standard details or specifications please visit our website.

Exclusion of Liability

RHEINZINK GmbH & Co. KG takes account of state-of-the-art technology, product development and research at all times in its technical opinions. Such comments or recommendations are based on installation as is possible in standard cases in a European climate, specifically the indoor climate prevailing in Europe. We are of course unable to cater for all conceivable circumstances, which may call for restrictions and/or further measures in individual cases. This means that on no account are such comments provided by RHEINZINK GmbH & Co. KG any substitute for the advice or planning offered by an architect/consultant or contractor in charge of a specific building project under consideration of the specific circumstances prevailing on site.

Usage of documentation made available by RHEINZINK GmbH & Co. KG constitutes a service for which no liability can be assumed for losses or further claims of whatever nature. This does not affect liability arising in the case of intent, gross negligence or injury to life, limb or human health. Claims to compensation governed by the German Product Liability Act shall be likewise by unaffected thereby.

6th edition

© 2020 RHEINZINK GmbH & Co. KG

All rights reserved. No part of this book may be reproduced in any form without written permission of RHEINZINK GmbH & Co. KG.

Foreword

This document describes the use of RHEINZINK-Shiplap Panel. Although it forms the basis for proper planning and classical application solutions, it is no more than a guide for users. The detailed drawings included here describe solutions which are feasible at a practical level.

We should like to explicitly point out that in actual practice it may not be possible to create the type of cladding illustrated in this document – or not to their full extent. In this context every situation should be examined in detail by the planner in charge. It is necessary here to take account of the system-specific effects on the property and local/climatic conditions as well as the requirements in terms of building physics. Compliance with the application techniques and specifications described here does not release users from any responsibility in this regard.

This document is based on our practical experience and represents the latest findings from research and development, recognised standards and state-of-the-art technology. We reserve the right to make changes at any time in the course of further development.

Please also note our information on the material and its processing on our websites.

If you have any queries or suggestions, please contact your customer advisor or get in touch with your local RHEINZINK sales office. All contact data can be found on our homepage www.rheinzink.com/contact

Datteln, May 2020

The RHEINZINK Product Lines	2.	PROFILE GROUPS
1. BUILDING PHYSICS	2.	RHEINZINK Profile Group Shiplap Panel ST 40 Structural Load Tables
1. Function of rear-ventilated Facades	2.1	Profile Geometry
1.1 Windproof building Envelopes	2.1.1	RHEINZINK-Shiplap Panel, horizontal Installation
1.2 Weather Protection	2.2	Joint Formation
1.3 Moisture	2.2.1	Horizontal Installation of Panels
1.4 Thermal Economy	2.3	Accommodation of thermal linear Expansion in Facade Claddings
1.4.1 Thermal Insulation	2.4	Substructure
1.4.2 Summer thermal Insulation	2.5	Fixing
1.4.3 Thermal Bridges	2.5.1	EJOT®self-drilling Screws
1.5 Fire Protection	2.5.2	EJOT® blind Rivet with large Shoulder
1.6 Rear-ventilation	2.5.3	EJOT® blind Rivet
1.6.1 Air intake and exhaust Openings	2.6	Detailed Design
1.7 Soundproofing	2.7	Details
	2.7.1	General Information
	2.7.2	Pictogram
	2.8	Planning Grid
	2.9	Variations in Design
	2.10	Design Overview horizontal Sections Details horizontal Sections
	2.11	Design Overview vertical Sections Details vertical Sections
		Reference Projects Illustrations



● bright rolled

● blue-grey

● graphite-grey

RHEINZINK-CLASSIC

RHEINZINK-prePATINA

*ORIGINAL.
EXPRESSIVE.
PATINATES OVER TIME.*

*PRE-WEATHERED.
SELF-HEALING.
NATURAL.*

**ONE BRAND –
5 PRODUCT LINES**

**THE PERFECT
SOLUTION
FOR EVERY
REQUIREMENT**

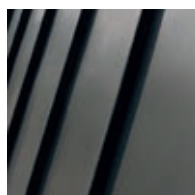
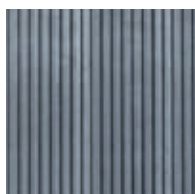

TITANIUM ZINC BRIGHT ROLLED:
PATINATES OVER THE YEARS. NATU-
RAL, VARIABLE SURFACE CHARACTER.

THE ONLY NATURALLY PRE-WEATH-
ERED SURFACE IN THE WORLD.
ZINC TYPICAL PATINA EX WORKS.
100% NATURAL, 100% RECYCLABLE.

- skygrey
- basalte

RHEINZINK-GRANUM

NOBLE.
MATTE FINISH.
MULTIFACETED.

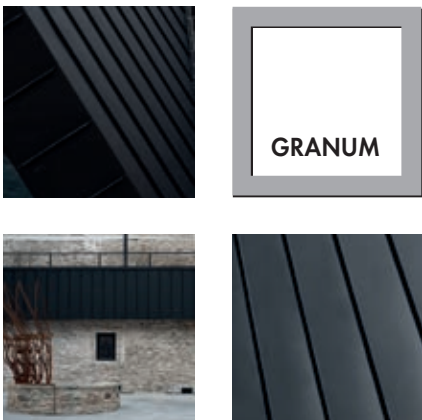

SKYGREY AND BASALTE. PURE, GREY ELEGANCE. URBAN DESIGN. PHOSPHATED SURFACE WITH COUNTLESS DESIGN OPPORTUNITIES.

- gold
- brown
- blue
- red
- green
- black

RHEINZINK-PRISMO

GLAZED.
DYNAMIC.
ADAPTABLE.

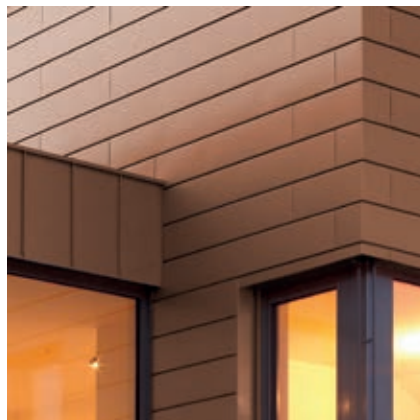

AESTHETIC, HARMONIOUS MATCH WITH ITS SURROUNDINGS. SUBTLE COLOUR VARIETY FOR A UNIQUE LOOK. SEMI-TRANSPARENT.

- pure-white
- pearl-gold
- moss-green
- nut-brown
- blue
- tile-red
- black-grey

RHEINZINK-artCOLOR

COLOURFUL.
LIVELY.
CREATIVE.

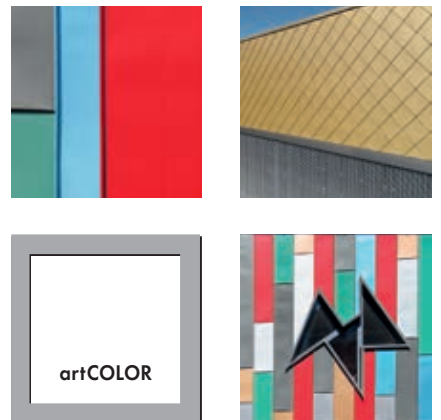

CREATIVE DESIGN POSSIBILITIES. INDIVIDUAL, EXPRESSIVE COLOUR COMPOSITIONS. COATED COLOUR VARIETY.

BUILDING PHYSICS

1. Function of rear-ventilated Facades

- Windproof Building Envelope
- Weather Protection
- Moisture
- Thermal Economy
- Fire Protection
- Rear-Ventilation
- Air Intake and Exhaust Openings
- Soundproofing

The rear-ventilated facade is a multi-layered system, which, when designed properly, guarantees permanent functional capability. By functional capability, we mean that all requirements pertaining to structural physics are met. This is described in detail below.

By separating the rainscreen facade from the thermal insulation and supporting structure, the building is protected from the weather.

The supporting outer walls and the insulation remain dry and thus fully functional. Even when driving rain penetrates open joints, it is quickly dried out as a result of the air circulation in the ventilation space. The bracket-mounted rear-ventilated facade protects the components from severe temperature influence. Heat loss in the winter and too much heat gain in the summer are prevented.

Thermal bridges can be reduced considerably.

In the case of rounded parapets and dormer girders, the substructure and thermal insulation should be protected from penetrating moisture with a suitable layer.

1.1 Windproof Building Envelope

This does not apply to the rear-ventilated facade, as this component itself cannot be windproof.

The building must be windproof before the rear-ventilated facade is installed. A solid brick or concrete wall will ensure that the building is windproof. Penetrations (e.g. windows, ventilation pipes, etc.) must be sealed from the building component to the supporting structure. In the case of a skeleton construction, the wall surface must also be sealed.

If the building envelope is improperly sealed (wind suction, wind pressure), there is a high degree of ventilation/energy loss, which, along with drafts, creates unpleasant room temperature. Dew or condensation can be expected on the leeward side of the building.

Air circulation in the room should be provided through air conditioning or by opening the windows.

1.2 Weather Protection

Rear-ventilated facade cladding protects the supporting structure, the water-proofed thermal facade insulation, and the substructure, from the weather.

Bracket-mounted rear-ventilated facades provide a high degree of protection from driving rain.

Because of the physical structure, it is impossible for the rain or capillary water transfer to reach the insulating layers. Furthermore, moisture can always be drawn out through the ventilation space. This allows the insulating layers to dry out quickly, without impeding thermal insulation.

1.3 Moisture

Rear-ventilated facade cladding provides protection from driving rain and moisture. Moisture penetration as a result of diffusion does not occur in the rear-ventilated facade.

When the supporting structure is windproof, the diffusion current density is too small to cause the dew point temperature to drop.

1.4 Thermal Economy

In order to understand the thermal economy of the rear-ventilated facade, we must first consider the various heat flow rates, as well as the air exchange between the rear-ventilation space and the outside air, separately, in terms of structural physics.

1.4.1 Thermal Insulation

In the winter, heat flow from the inside to the outside is referred to as a heat transfer co-efficient (U-value).

The smaller the value, the smaller the quantity of heat escaping to the outside. The U-value is determined by the heat conductivity of the thermal insulation and insulation thickness.

The high-grade thermal insulation is a contribution to environmental protection and pays for itself in a relatively short period of time through low heating costs.

1.4.2 Summer thermal Insulation

Summer thermal insulation should provide comfort: The amount of heat flowing from the outside to the inside should remain as small as possible. Proper thermal insulation, as well as a certain mass in the construction itself, will help to achieve this objective.

The advantage of a bracket-mounted, rear-ventilated facade, is that a large portion of the heat which streams onto the cladding is diverted through convective air exchange.

1.4.3 Thermal Bridges

Thermal bridges are elements of the building envelope, that have high thermal conductivity (have high U-values) and are continuous from the warm side to the cold side of the thermal insulation. Apart from general design-dependent thermal bridges of a building, e.g. protruding balconies, the installation of the substructure must be taken into account in the case of a rear-ventilated facade. Thermal bridges can be reduced significantly by installing an insulating strip between the supporting structure and the substructure (thermal break). Proper installation of the insulation reduces the formation of thermal bridges.

1.5 Fire Protection

Metal facades with a metal substructure and appropriate fasteners meet the highest requirements for non-combustibility (Building Material Class A1, DIN 4102). In the case of bracket-mounted, rear-ventilated facades, it may be necessary to install firestops.

1.6 Rear-Ventilation

The free ventilation cavity between the facade cladding and the layer behind it must be at least 20 mm. Tolerances and plumbness of the building must be taken into account. In some places, this rear-ventilation space may be reduced locally up to 5 mm – e.g. by means of the substructure or the unevenness of the walls.

1.6.1 Air Intake and Exhaust Openings

The rear-ventilation space requires intake and exhaust vent openings. These openings must be designed so that their functionality is guaranteed for the lifetime of the building. It cannot be hindered through dirt or other external influences. The openings are located at the lowest and highest point of the facade cladding, as well as in windowsill and window lintel areas, and penetrations. In the case of higher, multi-storey buildings, additional intake and exhaust vent openings should be provided (e.g. at each floor).

1.7 Soundproofing

To prove that a facade design is soundproof, the entire wall structure, as well as each building component (windows, etc.) must be defined. The use of proper static fasteners will prevent any potential noise development as a result of the cladding.

2. RHEINZINK Profile Group Shiplap Panel ST 40

The shiplap panel opens up a wide range of design options for planners as it can be installed horizontally or diagonally. The RHEINZINK-Shiplap Panel looks like wooden panelling but offers the benefits of a metal facade.

The shiplap panel is available in overall widths of 200-333 mm.

Technical Approval

The RHEINZINK-Reveal Panel System is subject to EN 14782 and is approved for use with substructure spacing ≤ 1.00 m (other support spacing possible on request). In Germany the façade system is additionally governed by the Con-

struction Products List B, Part 1 (edition 2015/2), section 1.0 relating to construction products subject to harmonised standards according to the Construction Products Directive, section. 1.4.10.1 Self-supporting roof covering and wall cladding elements for interior and exterior application made of sheet metal.

Static load tables

Load tables are based on DIN 18807 for profile section properties.

Deflection:

1/180 for façade components

Safety factor:

$g = 1.50$



(this is taken into account in the tables)



Units for loads and forces

The load tables indicate permissible forces and loads in kN/m^2 .



Deflection values in relation to span width are given for single span, double span or multi-span conditions.

The following indicators are used for display purposes:



Single span 
Double span 
Multi-span 

Span width in m		0.80	0.90	1.00	1.10	1.20	1.30	1.40	1.50
Permissible wind load in kN/m^2		1.97	1.56	1.26	1.04	0.88	0.75	0.64	0.56
		1.18	1.05	0.94	0.86	0.78	0.72	0.63	0.53
		1.34	1.30	1.17	1.07	0.97	0.84	0.74	0.65



ST 40-333, $t=1.00$ mm

Span width in m		0.80	0.90	1.00	1.10	1.20	1.30	1.40	1.50
Permissible wind load in kN/m^2		3.29	2.60	2.10	1.74	1.47	1.25	1.07	0.94
		1.97	1.75	1.57	1.44	1.30	1.20	1.05	0.88
		2.24	2.17	1.95	1.78	1.62	1.40	1.23	1.09

ST 40-200, $t=1.00$ mm

Span width in m		0.80	0.90	1.00	1.10	1.20	1.30	1.40	1.50
Permissible wind load in kN/m^2		2.42	1.92	1.55	1.28	1.08	0.92	0.79	0.69
		1.44	1.28	1.15	1.05	0.96	0.87	0.76	0.67
		1.63	1.45	1.31	1.19	1.09	1.01	0.93	0.82

ST 40-333, $t=1.20$ mm

Span width in m		0.80	0.90	1.00	1.10	1.20	1.30	1.40	1.50
Permissible wind load in kN/m^2		4.04	3.20	2.59	2.14	1.80	1.54	1.32	1.15
		2.40	2.14	1.92	1.75	1.60	1.45	1.26	1.12
		2.72	2.42	2.19	1.98	1.82	1.69	1.55	1.37

ST 40-200, $t=1.20$ mm

Table 4: Load table for shiplap panel

Basis for design: uniformly distributed load, including the dead load of the profile

Safety factor: 1.50

Tensile yield strength: 100 N/mm^2

Width of support profile: ≥ 50 mm

DIN 18807/experimental testing at the University of Karlsruhe, Germany

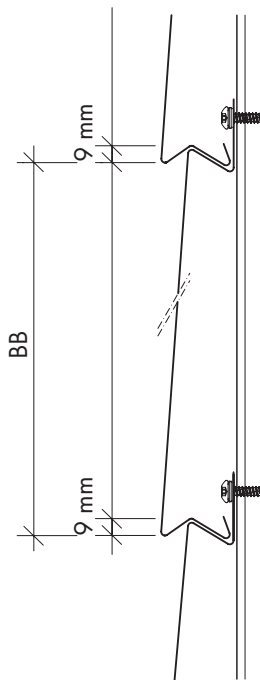

System section

2.1 Profile Geometry

Metal thickness
 $s = 1.00 \text{ mm}/1.20 \text{ mm}$

Cover width ST 40 $t = 1.00 \text{ mm}$	Weight
200 mm	11.66 kg/m ²
225 mm	11.17 kg/m ²

Cover width ST 40 $t = 1.20 \text{ mm}$	Weight
250 mm	12.84 kg/m ²
300 mm	12.21 kg/m ²
333 mm	11.76 kg/m ²

Cover widths of 200-333 mm
 All intermediate sizes in increments of 1 mm are possible.
 We recommend using the metal thickness 1.20 mm with overall widths of 250 mm and over.

Outdoor Applications

- Facades
- Parapets

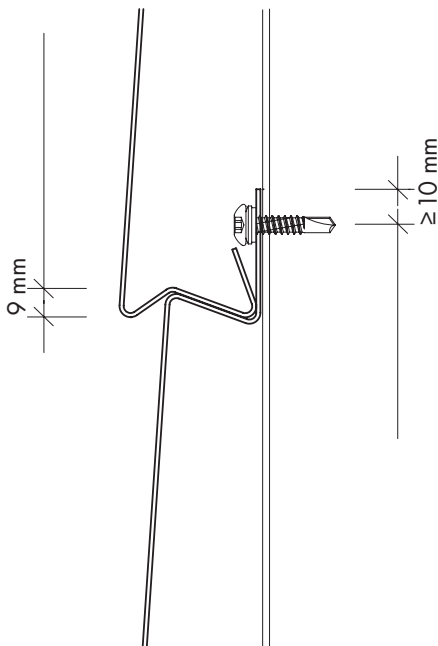

Fixing

Panels are directly riveted/screwed to the substructure, with the upper spring being used for attachment.

Linear expansion is restricted by limiting the length of the facade panel and is accommodated by deflection of the substructure.

Dimensions

- Drawings: Measurements in mm
- Panel designation: ST 40-287 (example)
- Standard length: $\leq 4000 \text{ mm}$
- A: Bay width
- BB: Cover width = bay width
- F: Joint width
- S: Face width

Tolerances

According to RHEINZINK works standard

Installation

- It is recommended reinforcing panels at both ends with stopends.
- The overlap between the bottom and top edge of each panel is 9 mm.
- Panels (BB) are manufactured with a tolerance of 0 to $< 1 \text{ mm}$ in relation to the measurements ordered.





Residential Building Duisburg-Hamborn e. G., Duisburg, Germany

**2.1.1 RHEINZINK-Shiplap Panel,
horizontal Installation**

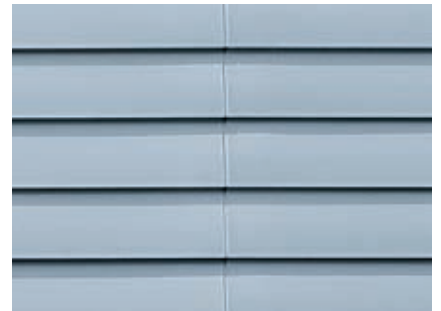

Elevation/Detail of a shiplap panel facade with a slave profile



Bonn University Clinic, Bonn, Germany

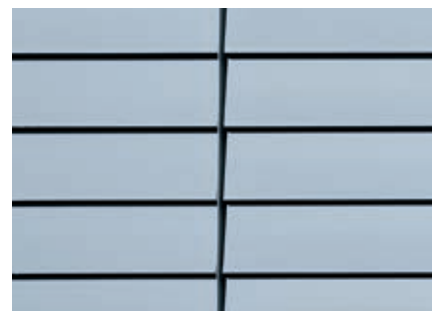

Detail of a shiplap panel facade with a shadow gap/vertical joint profile

JOINT FORMATION

2.2 Joint Formation

2.2.1 Horizontal Installation of Panels

2.2.1.1 Vertical Joint

A: Shadow Gap Profile

Panels are closed with side stopends, which are based on the profile geometry of the shiplap panels. The shadow gap is emphasised by a profile which is installed vertically and folded in three dimensions.

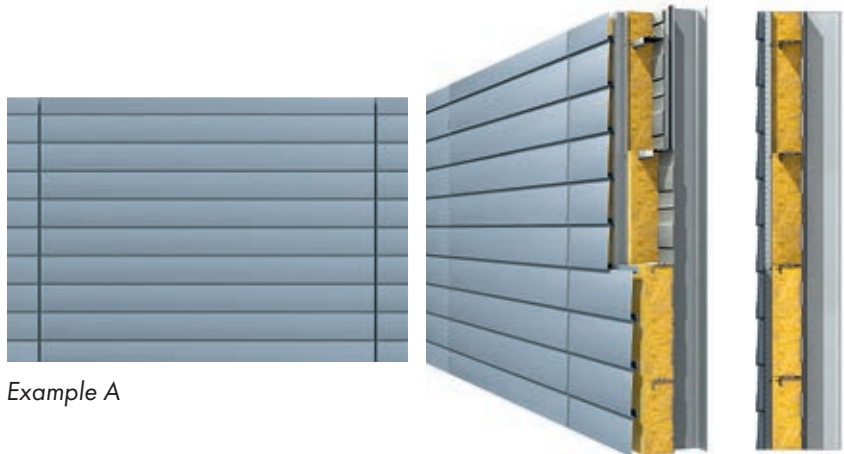

Example A

B: Joint with a vertical Joint Profile

This vertical joint profile divides up the individual fields of panelling with a clear break.

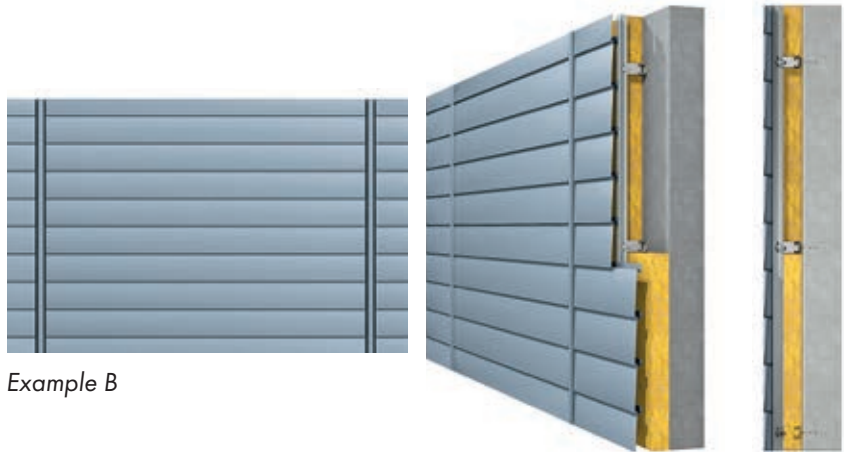

Example B

C: Slave Profile with Stopends

Behind the joint there is a slave profile that matches the profile geometry. A very unobtrusive joint in terms of design, this solution highlights the horizontal lines of the panels.

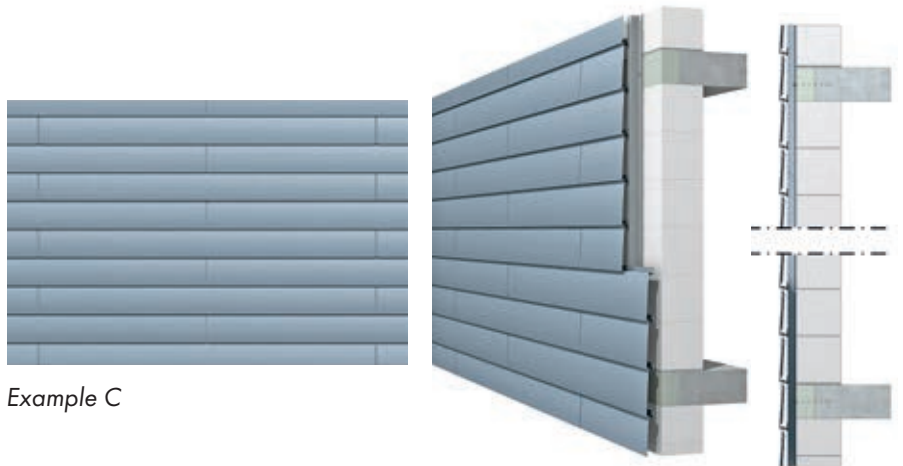

Example C

D: Butt Joint

This vertical joint separates the individual fields of panelling with expansion joints.



Example D

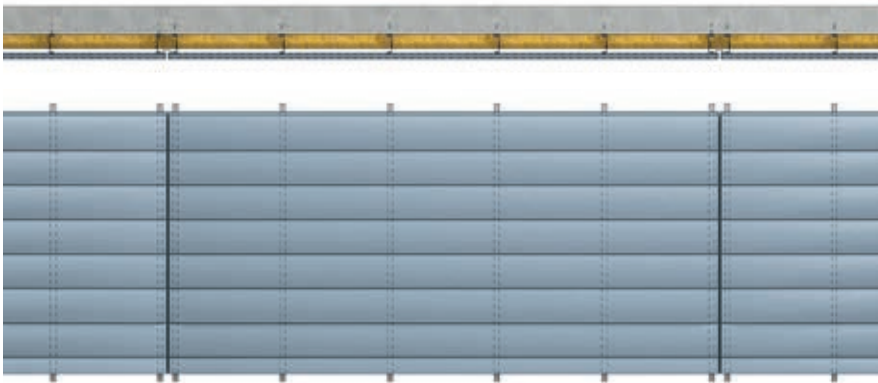

Example A



Example B

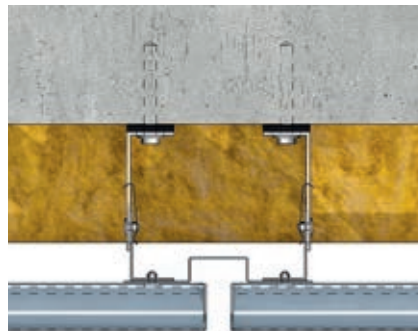

Detail Example B

2.3 Accommodation of thermal linear Expansion in Facade Claddings

- Linear expansion of the facade profiles is accommodated by separating the facade sections with expansion joints.
- Structurally connected fields should not exceed 4000 mm in length. Any exceptions must be approved by the Applications Technology department.
- If joints are to accommodate linear expansion, fixing to the substructure must be designed accordingly.
- The substructure must be designed so that each facade field can expand and contract independently at the expansion joint.

This is illustrated by the two examples of facade design given below:

Example A

Large cladding components each form a field, which is fixed in place separately from the next field using expansion joints.

Example B

This type of cladding is characterised by the installation of semi-staggered vertical joints. For the substructure to be designed correctly, a vertical rail must be fitted to the right and left of the butt joint. This ensures that every panel can expand and contract independently of the others.

SUBSTRUCTURE

2.4 Substructure

RHEINZINK facade systems are normally installed on substructures consisting of single, two- or multi-part non-ferrous metal systems. Apart from efficiency and the structural advantages provided by these systems, they also guarantee control and monitoring of fastening patterns and compliance with fire protection regulations. Moreover, the two- and multi-part systems enable building tolerances to be adjusted without difficulty.

The architectural appearance of the profiles determines the design of the substructure. Before the substructure is constructed, those concerned must determine the appropriate design, otherwise – inevitably – the design would determine the architecture.

Note:

Use of wood as a substructure for large façade surfaces in system technology is not recommended because of its behaviour when damp and difficulty in adjusting tolerances.

However, a dried wooden substructure is definitely suitable for small surface applications such as dormers, fascias and gable walls.

The location and orientation of the fixed and sliding points for metal substructures must be determined based on the type of cladding, the surface and length of the panels.

With single substructure systems, the disadvantages certainly outweigh the advantages, such as:

- Inability to accommodate building tolerances
- Large thermal bridges

All technical problems are solvable when two-/multi-part systems are used:

- Local thermal bridges only
- Rear-ventilation throughout is guaranteed

However, the expensive and elaborate design coupled with the fact that two or more installation procedures must be implemented must be taken into consideration.

Two-part systems constitute the “happy medium”:

Advantages

- Cost-effective
- Easy accommodation of building tolerances
- Local thermal bridges only

Disadvantages:

- Two installation procedures
- Depending on the detailing requirements additional costs can occur



Single substructure



Two-part substructure



Multi-part substructure

2.5 Fixing

Fixings are parts designed to mechanically fasten the cladding to the substructure.

The distance between the edge and connections or fixings in the substructure must be at least 10 mm. Only corrosion-resistant fixings which guarantee a long service life should be used here.



2.5.1 EJOT® self-drilling Screws

Application

Self-drilling screws used to join

- RHEINZINK-Shiplap Panels to
- Steel substructures
1.5 - 4.0 mm
- Aluminium substructures
1.5 - 4.0 mm

JT3 - FR - 6 - 5.5 x 25 - E11



Designation	Ø x mm	Length mm	Drilling capacity t _I + t _{II} mm	Clamping thickness mm
JT3 - FR - 6	5.5 x	25	min. 0.63 + 1.5 max. 2.0 + 4.0	0 - 7.0



2.5.2 EJOT®

blind Rivet with large Shoulder

Aluminium (Al) rivet sleeve
Rivet shaft of stainless steel
100% secure connection

Application

- Blind rivet used to secure
- RHEINZINK-Shiplap Panels
 - Steel or aluminium structural deck profiles
- to
- Steel substructures
 - Aluminium substructures

Blindniet K14 - Al/E - 5.0 x 8.0

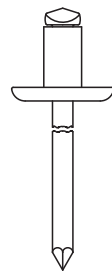

Designation	Ø x mm	Length mm	Clamping range mm	Drill hole Ø mm
Blind rivet K14 - Al/E -	5.0 x	8.0	2.5 - 4.5	5.1
	5.0 x	10.0	4.5 - 6.0	5.1
	5.0 x	12.0	6.0 - 8.0	5.1
	5.0 x	18.0	12.0 - 14.0	5.1



Note

Use a rivet jig at sliding points.

2.5.3 EJOT® blind Rivet

Aluminium (Al) rivet sleeve
Rivet shaft of stainless steel
100% secure connection

Application

Blind rivet used to secure secondary components, e.g. butt straps.

Blind rivet Al/E - 4.8 x 10



Designation	Ø x mm	Length mm	Clamping range mm	Drill hole Ø mm
Blindniet Al/E -	4.8 x	10.0	0.5 - 6.5	4.9
	4.8 x	15.0	4.5 - 11.0	4.9
	4.8 x	25.0	11.0 - 19.5	4.9

DETAILED DESIGN

2.6 Detailed Design

Design of the details has a major impact on the facade. Building profiles are required for most corners, jambs and connections/terminations and need to be coordinated when working out the details of the design. This is illustrated by two fundamental variations in design (see below).

Face Width of Building Profiles

This ranges from sharp-edged profiles to those several centimetres in width. Careful planning allows all termination and frame profiles to be given a standard width or varied on a proportionate basis as required.

Projection of Profiles

Depending on the detailed design, profiles can either be flush with the facade or project beyond it.

The overview illustrates two possible principles:

Profile Group 1

A relatively wide vertical joint profile (face width approx. 60 mm) which terminates flush with the facade is used here as the building profile.

Profile Group 2

The shiplap panel is used at the window jamb to emphasise the profile geometry of the shiplap panels.



Profile group 1



Profile group 2

2.7 Details

2.7.1 General Instructions

Third Party Trades

Connections of façade claddings to third party trades are necessary and unavoidable in most cases to ensure impermeability. Because of the warranty obligations on the part of the craftsman, sub-contracting connections and fasteners to third party trades (e.g. windows), must always be approved by the project manager of the trade in question.

Please keep the location of the scaffold anchors in mind during planning/design.

Wall Structure

The layered construction is equal to a rear-ventilated metal façade. A solid brick/concrete wall or stud wall with sheathing serves as the supporting structure.

Substructure

See Chapter 2.4

Load Effect

In the case of two-dimensional cladding profiles (all panel types) that are only fastened on one side, flanged backfolds are required to provide additional reinforcement for all profiles in exposed building locations.

Installation Instructions

We will not go into installation details here, because, when it comes right down to it, these are strongly influenced by other trades when it comes to windows, structural steel construction, etc.

The installation processes must always be determined individually for each project, considering interfaces and the sequence of installation.

Notable deviations from the rule will be pointed out for various details.

Drip Edges

Standards and regulations must be taken into consideration in the detail design, e.g. drip edges above rendered façades (dirt as a result of pollution).

Diagonal Installation

RHEINZINK-Shiplap Panels can also be used for diagonal façade installation.

To a large extent, technical implementation of the design is commensurate with horizontal installation. Panel stopends must be fabricated on site.

2.8.2 Pictographs

Horizontal profiles (see chapter 2.10)

H1: Outside corner

H2: Inside corner

H3: Window jamb

H4: Expansion joint

Vertical profiles (see chapter 2.11)

V1: Base

V2: Window sill

V3: Window lintel

V4: Roof edge

Variations

In some cases, variations for the same detail are depicted (e.g. window lintel with/without shade).

These are identified and include additional explanatory texts or drawings.

Applicability

The details and designs depicted here are suggestions, which have been implemented on various projects. Responsibility must be taken for decisions made on detail suggestions, taking into account applicable standards and regulations, as well as the stylistic intentions of the planner for the project.

Building height	Drip edge distance mm	Dripe edge dittance to rendering mm	Cover required*
$h < 8$	≥ 20	≥ 40	≥ 50
$8 \leq h \leq 20$	≥ 20	≥ 40	≥ 80
$h > 20$	≥ 20	≥ 40	≥ 100

Drip edge distances and overhang dimensions for copings and flashings.

* The overhang dimensions also apply on the roof side. If the roofing foil is routed to the front edge of the facade without interruption, 50 mm overhang generally apply independent from the building height.

PLANNING GRID

2.9 Planning Grid
The Grid Principle in Facade Construction

A metal facade consists of components manufactured industrially with a high degree of precision. These components determine appearance through precise horizontal and vertical segmentation. Penetrations and terminations that are not matched/coordinated with the axis grid can have a disturbing effect. The following instructions serve to assist proper planning of facade segmentation:

Principles

As a rule, a differentiation should be made between new construction and renovations when discussing grid problems. In the case of new construction, the facade grid can be coordinated or matched to the design; penetrations such as windows, ventilation piping, etc. are always secondary.

In the case of renovations, the penetrations (e.g. windows) cannot be displaced or removed, so the grid must be coordinated with the penetrations.

When deviating from the grid, the following principles apply:

- At terminations, one should begin or end with an entire module (X or Y)
- Dimensional differences of max. 15 mm, are not noticeable.
- Dimensional tolerances, which cannot be corrected (X or Y dimensional change) must be compensated either in the windowsill or roof edge area.
- Adjustments or displacements of height coordinates can only be implemented in the roof edge or base area.

The principles used to segment a facade are illustrated using the example of a horizontal cladding.

- A: Bay width
- BB: Cover width = bay width

Module Y

Y corresponds to the smallest unit of the facade segmentation that repeats itself, e.g. the panel width. Grid module Y determines the precise location of penetrations and transitions. With shiplap panels dimension Y is freely selectable and is produced with cover widths ranging between 200 mm and 333 mm depending on the project.

The bay width/cover width is determined by the face view of the panel.

Dimension X

All of the sections marked with X are an integral multiple of selected module Y and, as a rule, correspond to the cover width of a profile.

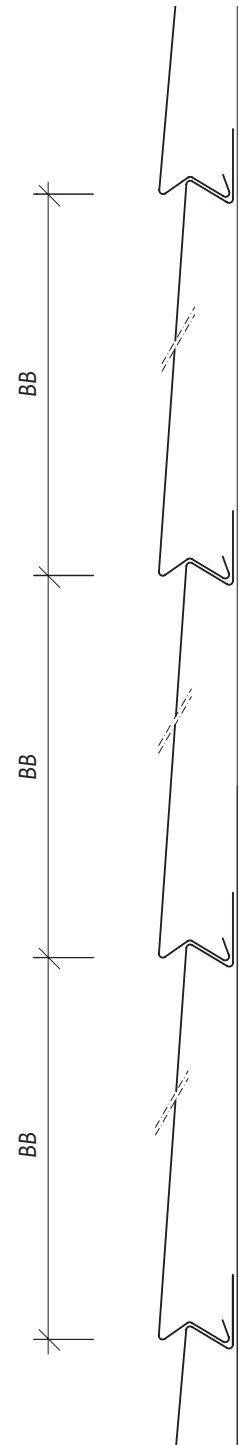
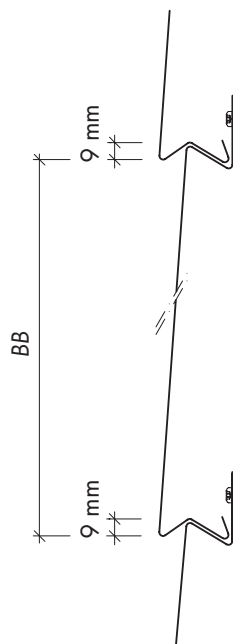

Panel as repeat

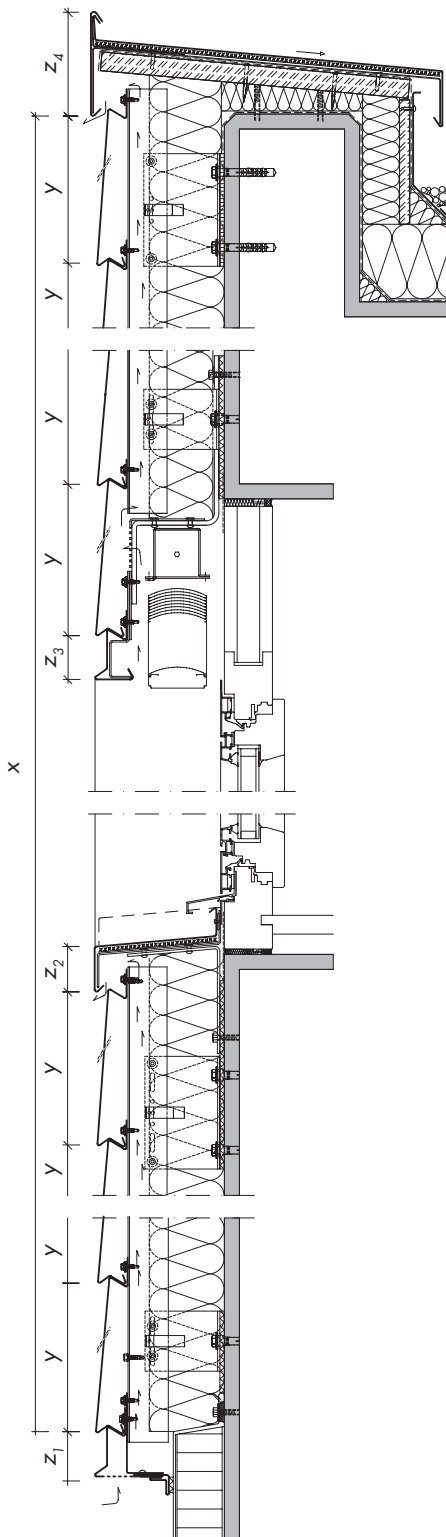

Position Z_4 : Roof Edge

Grid for new Construction, respectively, Renovation

If the height coordinates of the roof edge do not fit into the prescribed grid selected, the following corrective options can be selected:

- Change the roof edge profile/incline
- Raise or lower the parapet wall or the roof edge board
- Changing the X or Y module

Position Z_3 : Window Lintel

Position Z_2 : Windowsill

Grid Development for new Construction

- Determine the openings of the building shell
- Determine the window frame profile
- Determine window location
- Determine profile geometry of window connections
- Develop design details within the grid

Grid Development for Renovations

- Determine window frame profile, for new/old window
- Determine window location, for new/old window
- Determine profile geometry of window connections
- Develop design details within the grid

If the location of a window or detail does not fit the grid, the following options are available for correction:

- Change the profile geometry of the window jamb, the lintel profile of the window or the window sill
- Adjust the height or width of the window
- Change the slope of the windowsill

Position Z_1 : Base

Grid Development for new Construction, Respectively, Renovation

- Define potential deviations toward the top or bottom
- Define profile geometry of base detail in accordance with corner profiles

If the location of the base does not fit into the grid, the following corrective options can be selected:

- Shift the façade connection towards the top and/or bottom
- Change the profile geometry of the base profile
- Lower or raise the plinth masonry, if it exists or has been designed

VARIATIONS IN DESIGN

2.9 Variations in Design

Fascia with Shadow Gap

A two-section structure for the fascia offers constructional benefits while opening up greater scope for design. A two-section design allows profiles to expand freely. At the same time it can be seen from this example that the face of the fascia profile is visually segmented by a shadow gap. This gives an especially filigree look to the facade termination, so creating an impression of elegance.

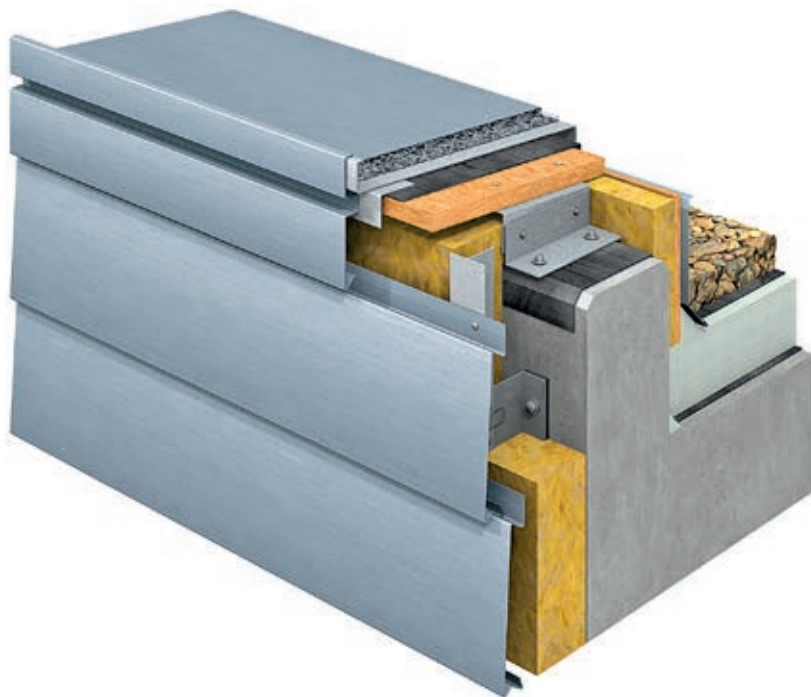

Fascia with Shiplap Panel

If you wish to further emphasise the horizontal segmentation and unmistakable structure of shiplap panelling, a two-section fascia solution makes this possible. Here the top shiplap panel acts as a fitting panel. It is inserted in the upfold of the fascia at the upper panel termination and fixed in place there.

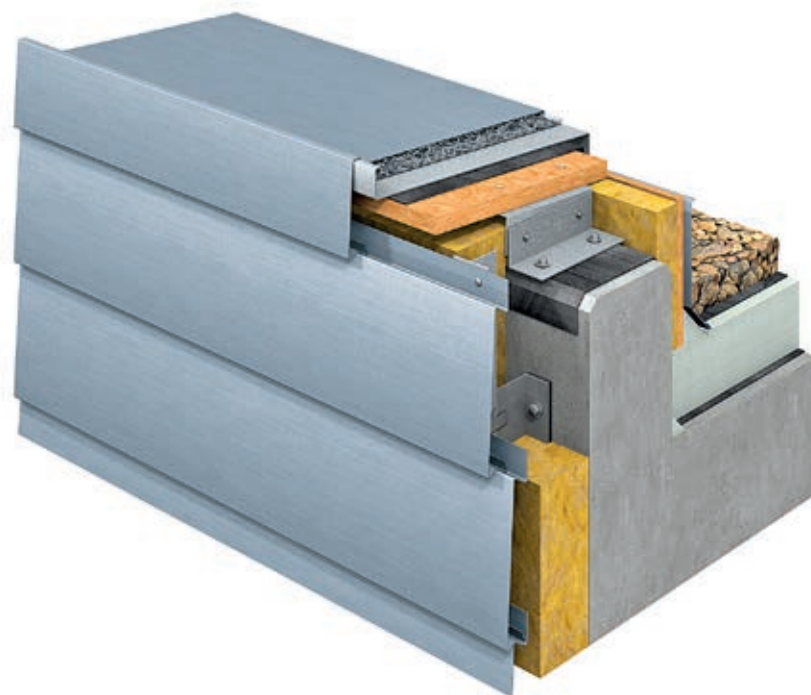

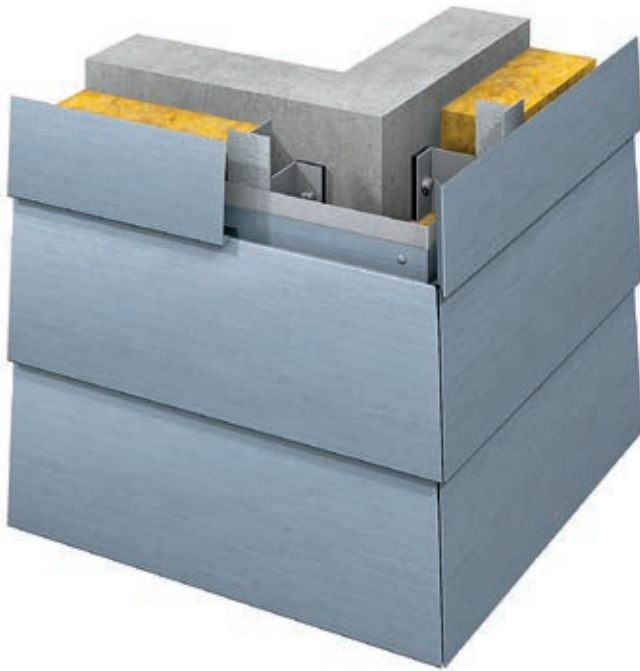

Corners

This corner variation emphasises the horizontal structure of the facade, creating an impression of tranquillity and elegance. Here the shiplap panels are provided with stopends, which correspond to the geometry and permit mitre joint installation. Realisation of this detail should be taken into account by the planner in good time and calls for a high level of manual skill on the part of the installer.

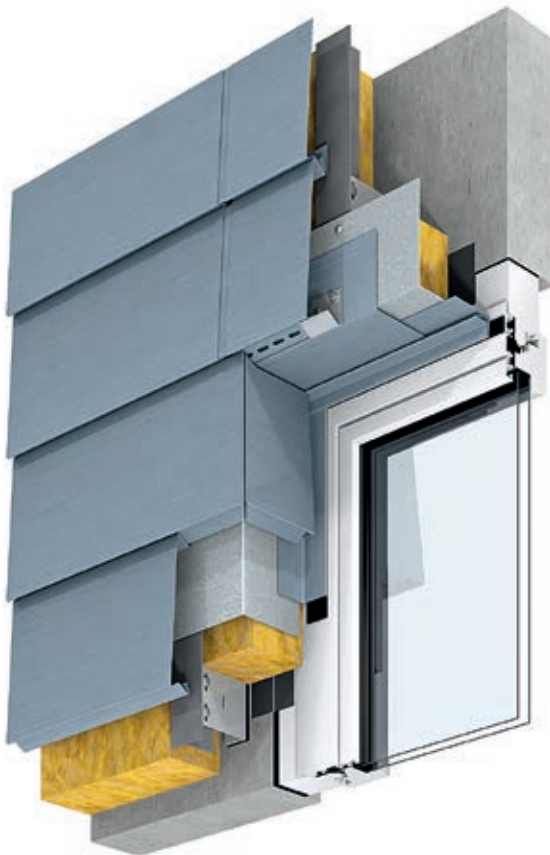

Lintel

This detail reflects the reduced, horizontally accentuated design of the facade. The planner has intentionally dispensed with the lintel and jamb profiles that would emphasise the window opening. The shiplap panel is inserted in the window jamb, with a partly perforated shiplap panel being used here as the lintel profile. During installation special attention should be given to coordinating the individual steps involved in assembly.

SHIPLAP PANEL, DESIGN AND APPLICATION

2.10 Design, horizontal Sections

Detail H1: Outside corner

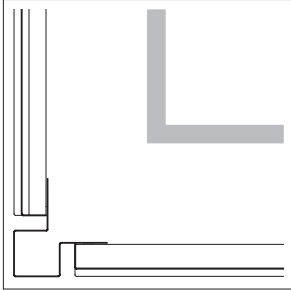

H1.1

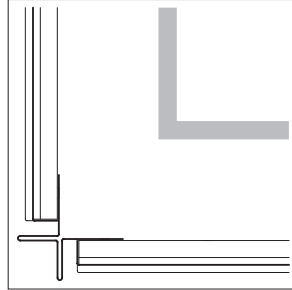

H1.2

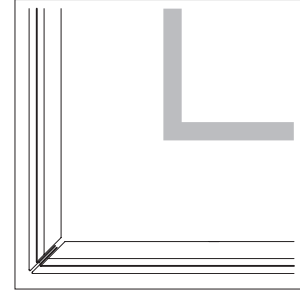

H1.3

Detail H2: Inside corner

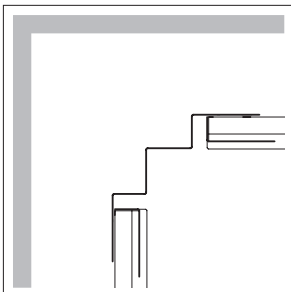

H2.1

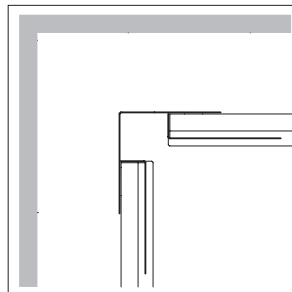

H2.2

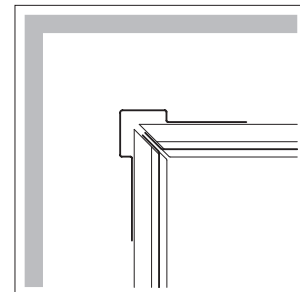

H2.3

Detail H3: Window jamb

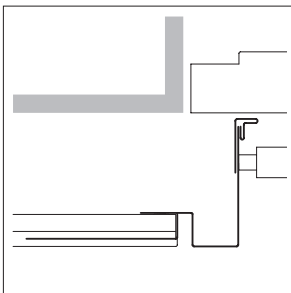

H3.1

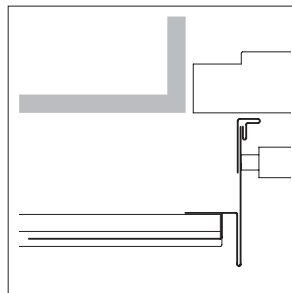

H3.2

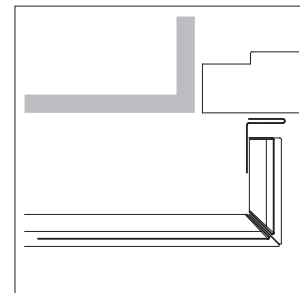

H3.3

Detail H4: Expansion joint

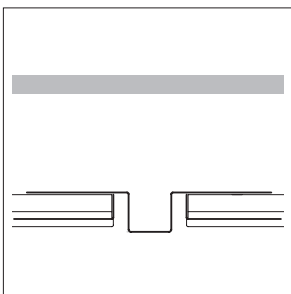

H4.1

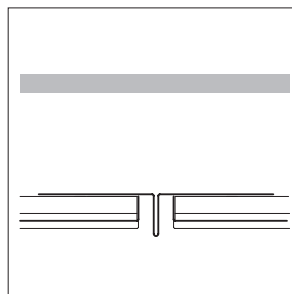

H4.2

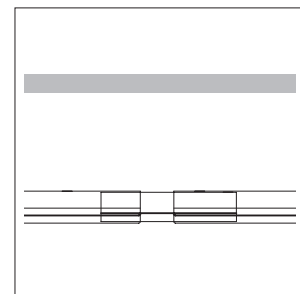

H4.3

SHIPLAP PANEL, DESIGN AND APPLICATION

DESIGN

DETAIL H1, OUTSIDE CORNER

H1.1

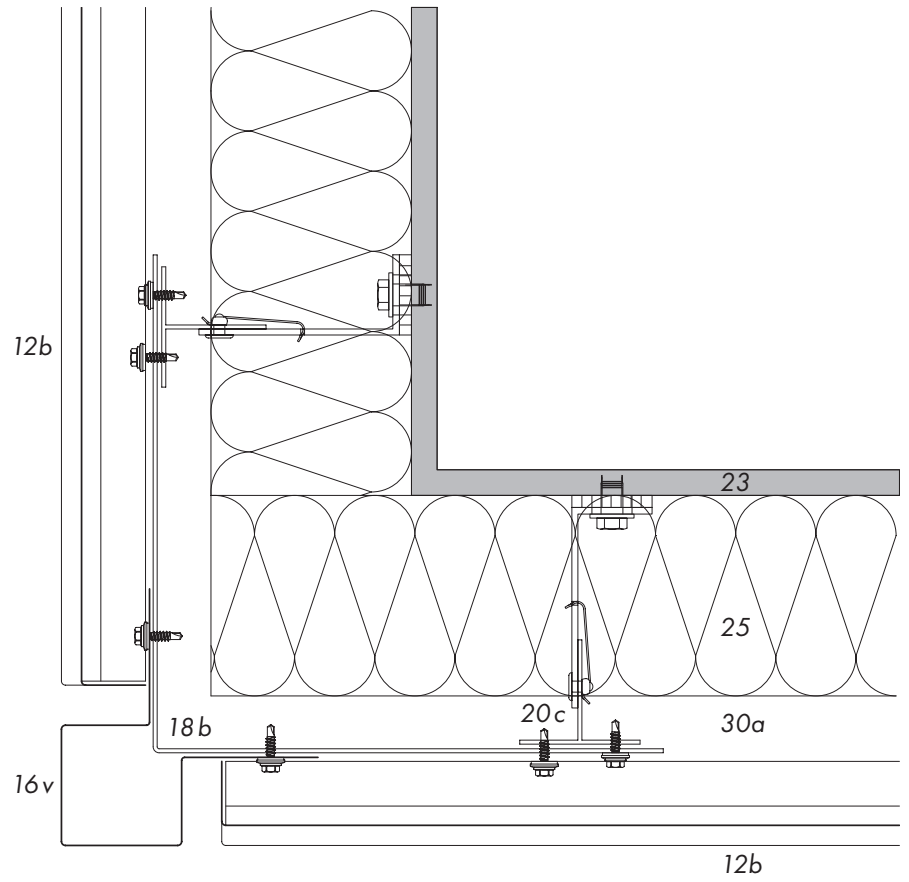

H1.2

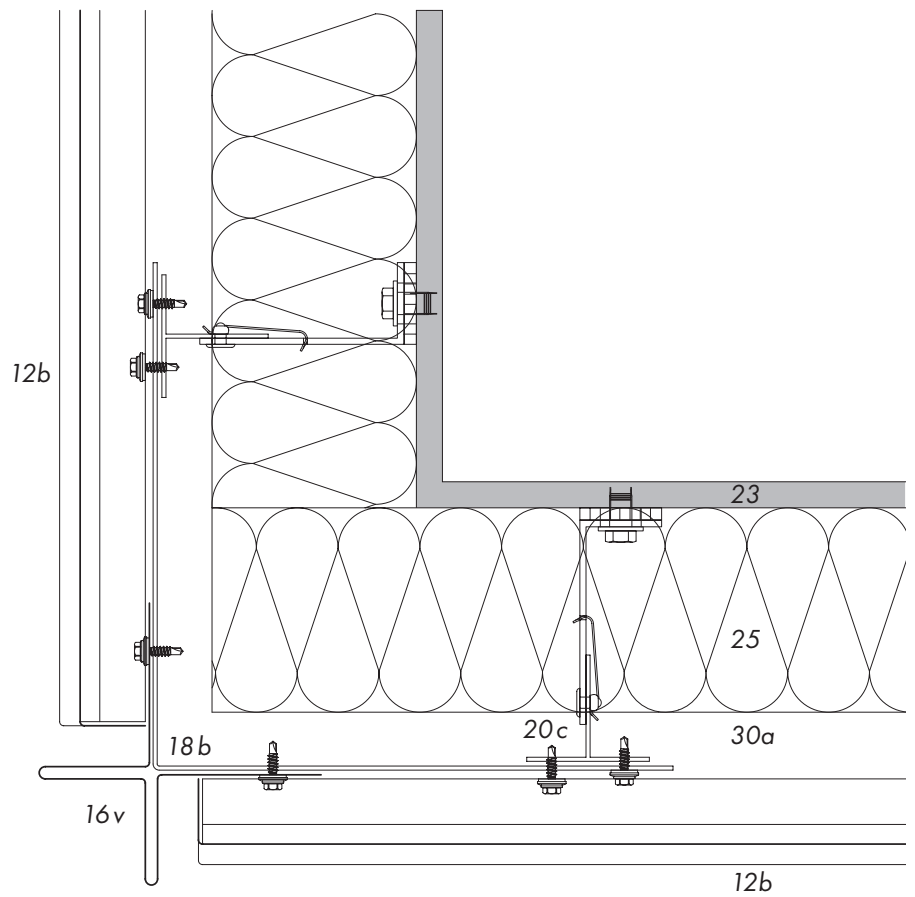

H1.3

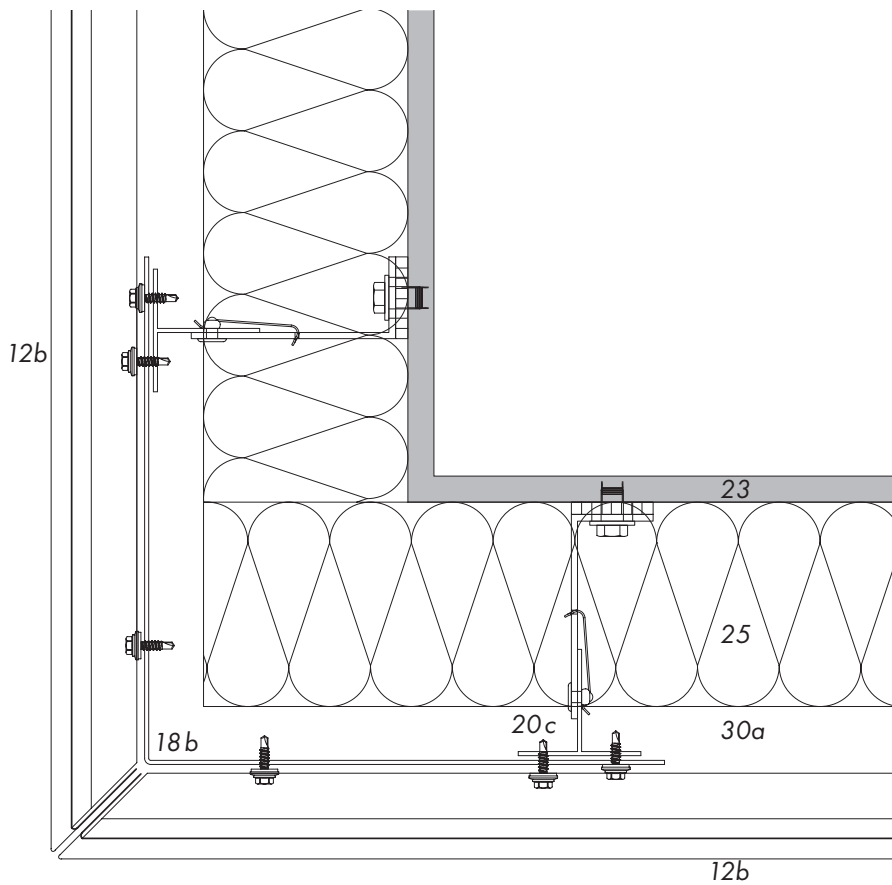
**Detail H1: Outside Corner**

- 12 RHEINZINK-Shiplap Panel ST 40
 - b Standard panel, with stopend
- 16 RHEINZINK-Building Profile
 - v Corner profile
- 18 Support Profile
 - b Aluminium
- 20 Substructure
 - c Bracket system,
with thermal break*
- 23 Supporting Structure
- 25 Thermal Insulation
- 30 Ventilated Air Space
 - a Depth of air space ≥ 20 mm

* Manufacturer's guidelines must be observed.

SHIPLAP PANEL, DESIGN AND APPLICATION

DESIGN

DETAIL H2, INSIDE CORNER

H2.1

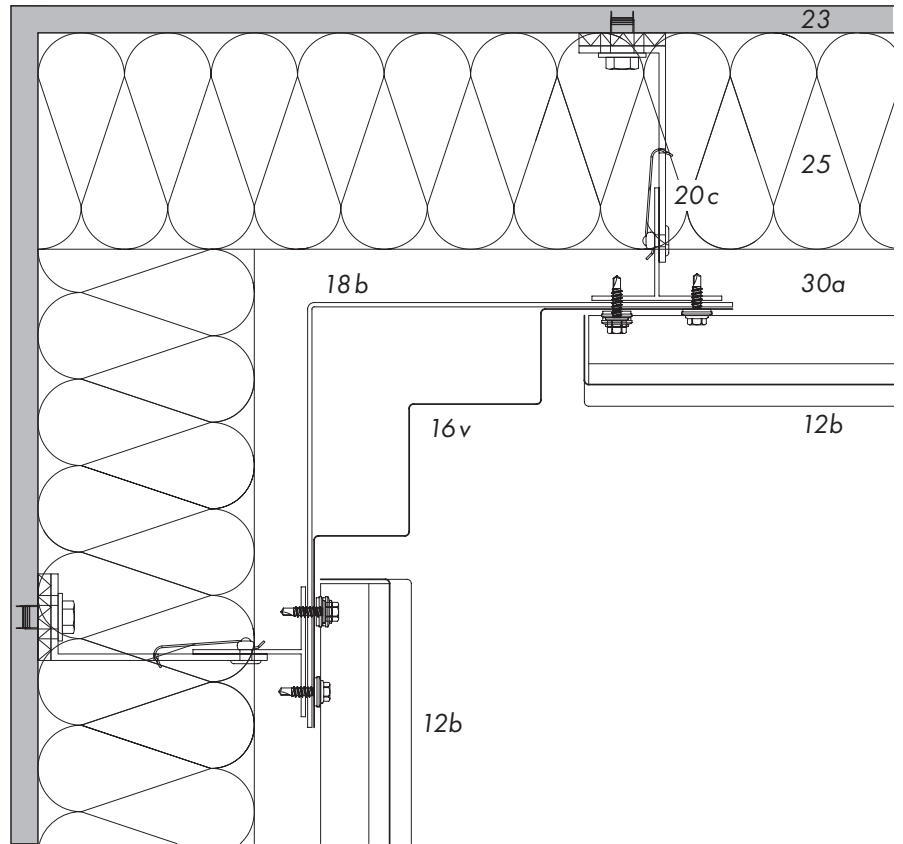

H2.2

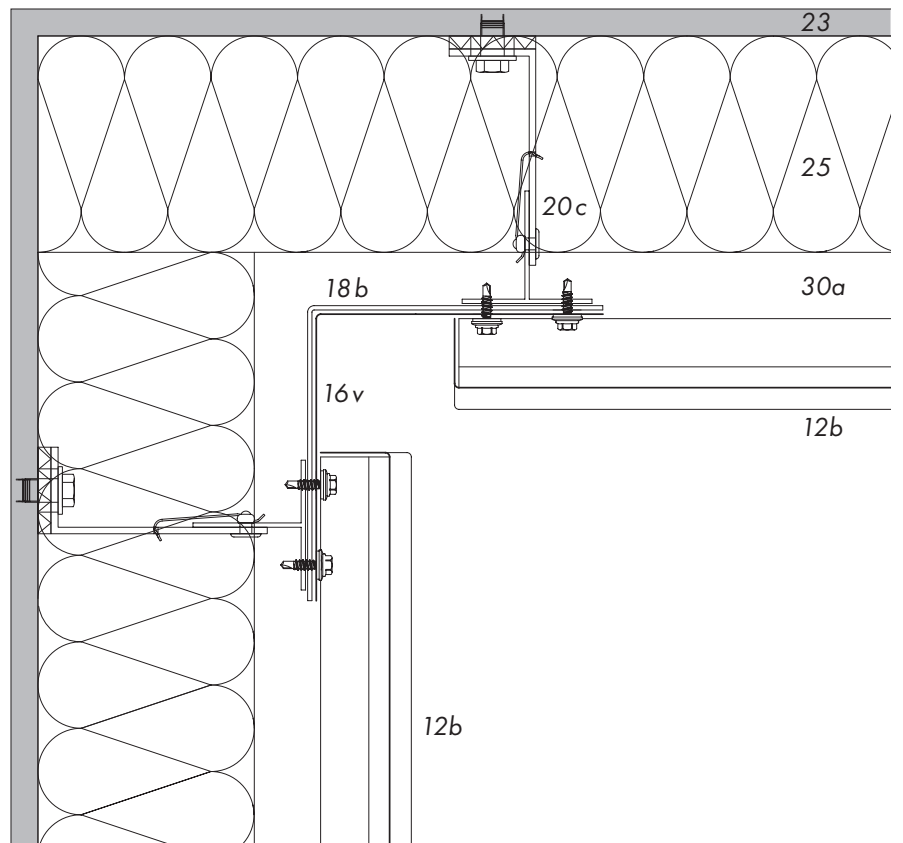

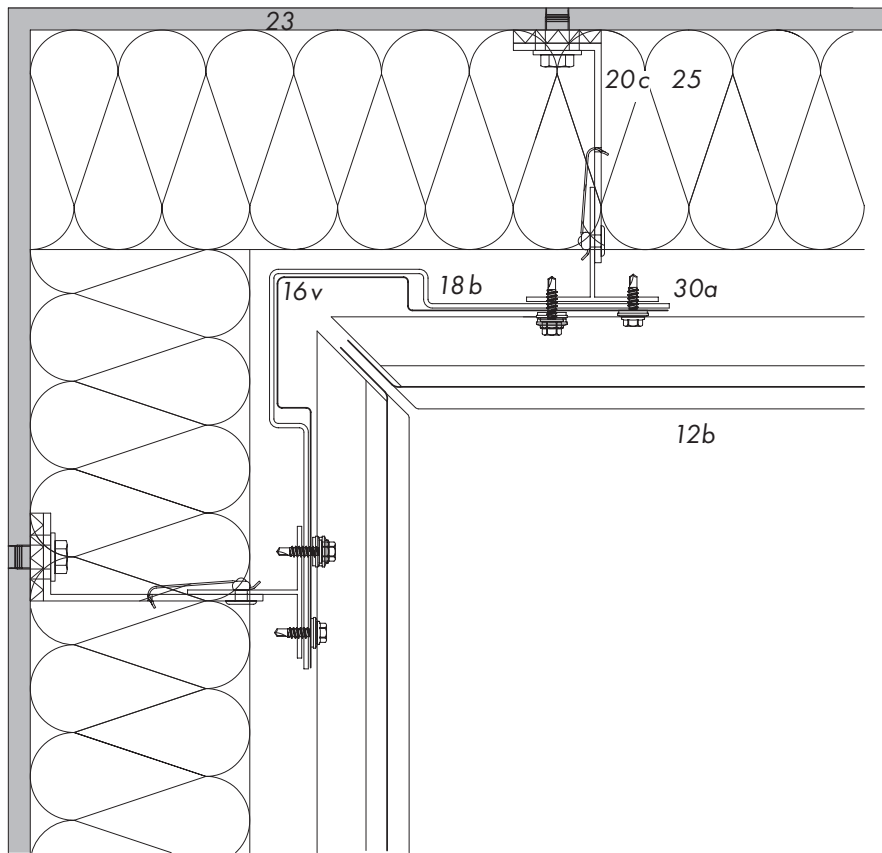

H2.3

Detail H2: Inside Corner

- 12 RHEINZINK-Shiplap Panel ST 40
 - b Standard panel, with stopend
- 16 RHEINZINK-Building Profile
 - v Corner profile
- 18 Support Profile
 - b Aluminium
- 20 Substructure
 - c Bracket system, with thermal break*
- 23 Supporting Structure
- 25 Thermal Insulation
- 30 Ventilated Air Space
 - a Depth of air space ≥ 20 mm

* Manufacturer's guidelines must be observed.

SHIPLAP PANEL, DESIGN AND APPLICATION

DESIGN

DETAIL H3, WINDOW JAMB

H3.1

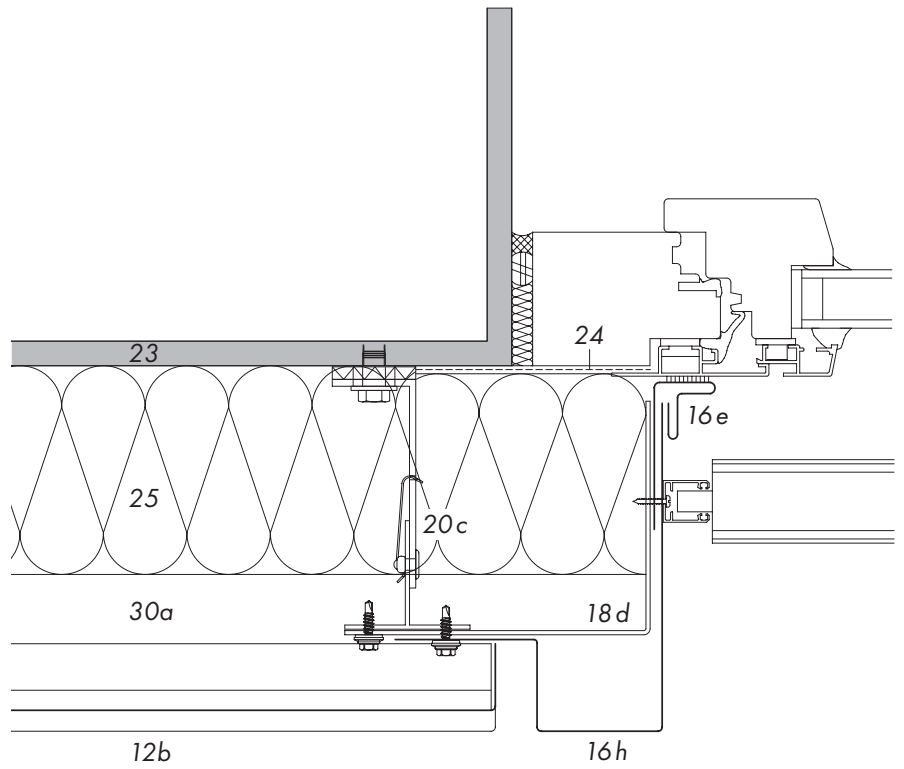

H3.2

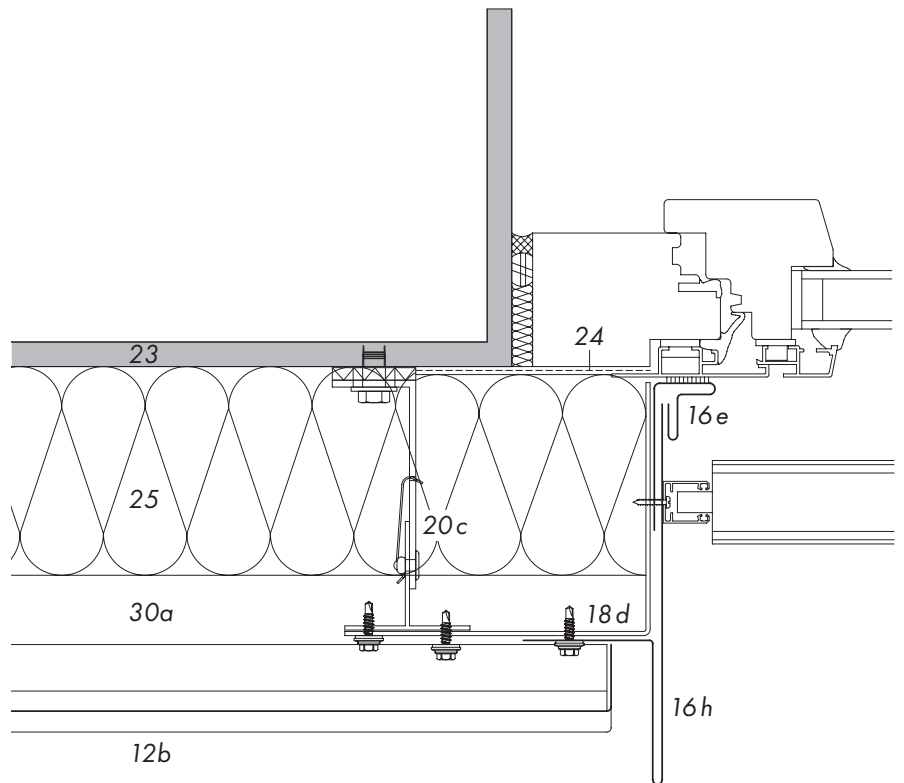

H3.3

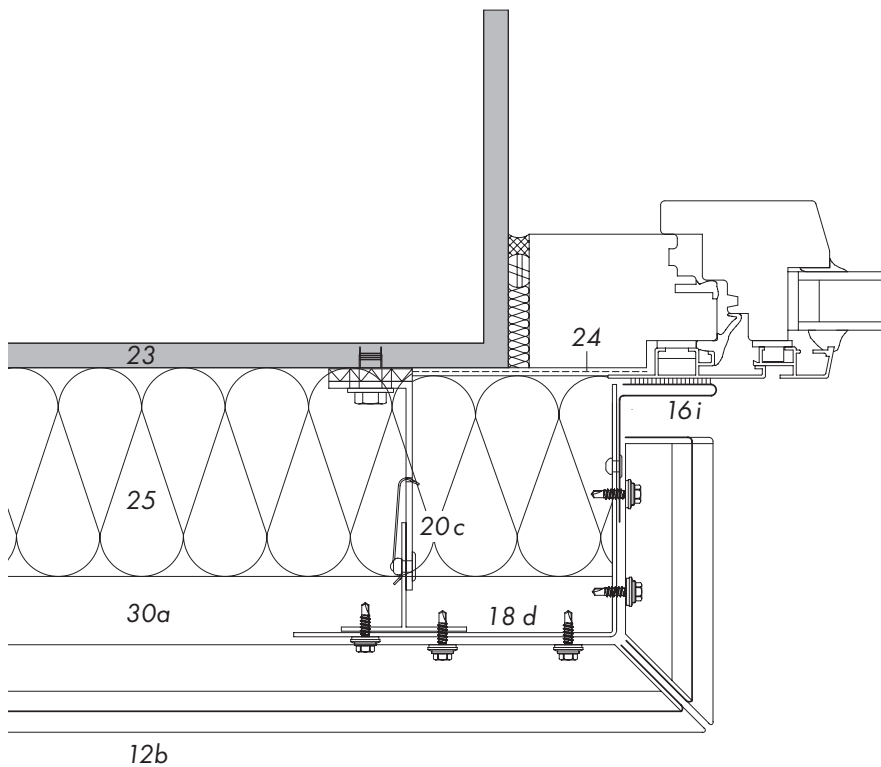
**Detail H3: Window Jamb**

- 12 RHEINZINK-Shiplap Panel ST 40
 - b Standard panel, with stopend
- 16 RHEINZINK-Building Profile
 - e Receiver strip, with sealant tape
 - h Jamb profile
 - i Connection/termination profile, with sealant tape
- 18 Support Profile
 - d Aluminium*
- 20 Substructure
 - c Bracket system, with thermal break**
- 23 Supporting Structure
- 24 Window Foil
- 25 Thermal Insulation
- 30 Ventilated Air Space
 - a Depth of air space ≥ 20 mm

* If fire breaks are required use galvanised steel ≥ 1 mm

** Manufacturer's guidelines must be observed.

SHIPLAP PANEL, DESIGN AND APPLICATION

DESIGN

DETAIL H4, EXPANSION JOINT

H4.1

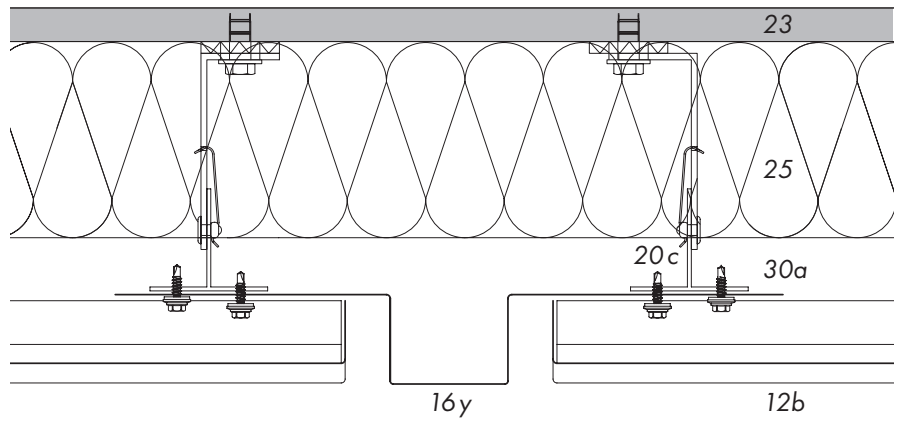

H4.2

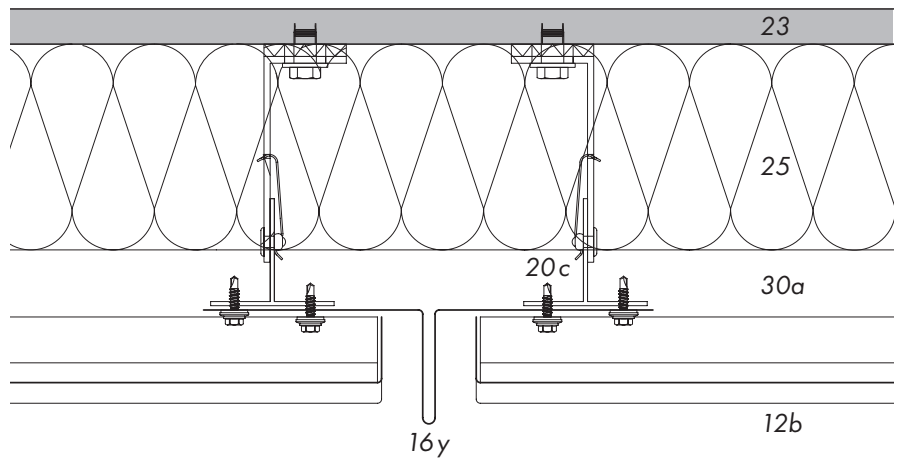

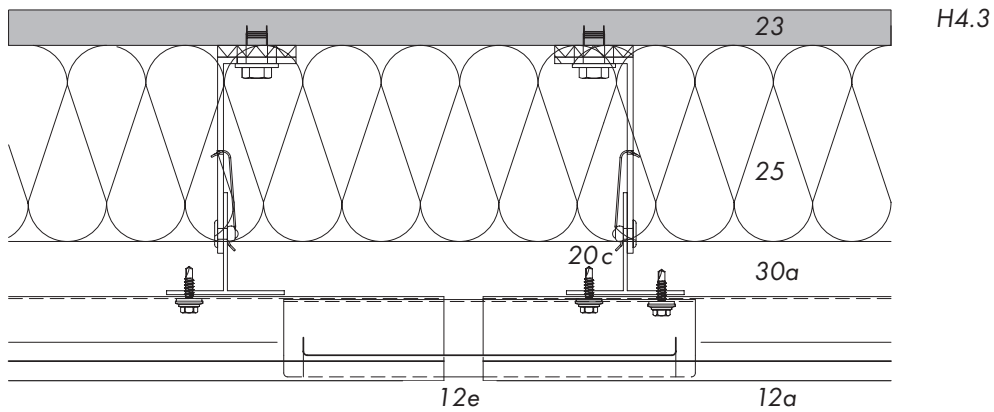
**Detail H4: Expansion Joint**

- 12 RHEINZINK-Shiplap Panel ST 40
 - a Standard panel
 - b Standard panel, with stopends
 - e Slave profile, with stopends
- 16 RHEINZINK-Building Profile
 - y Vertical joint profile
- 20 Substructure
 - c Bracket system,
with thermal break*
- 23 Supporting Structure
- 25 Thermal Insulation
- 30 Ventilated Air Space
 - a Depth of air space ≥ 20 mm

* Manufacturer's guidelines must be observed.

SHIPLAP PANEL, DESIGN AND APPLICATION

2.11 Design, vertical Sections

Detail V1: Base

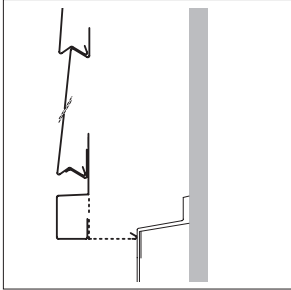

V1.1

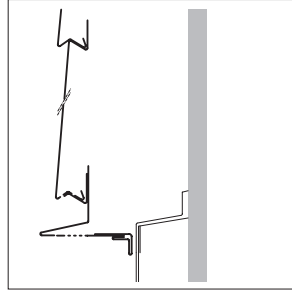

V1.2

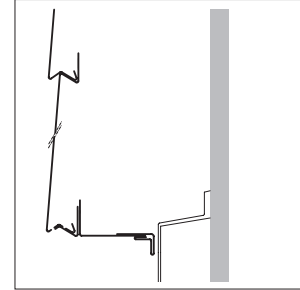

V1.3

Detail V2: Window sill

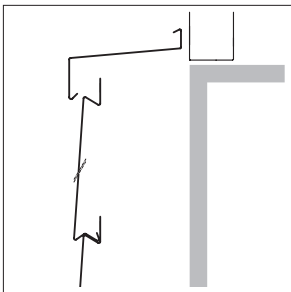

V2.1

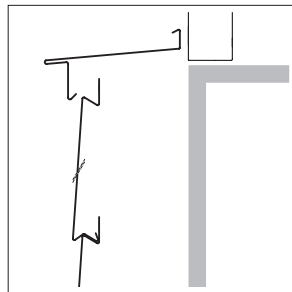

V2.2

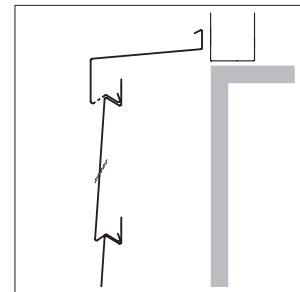

V2.3

Detail V3: Window lintel

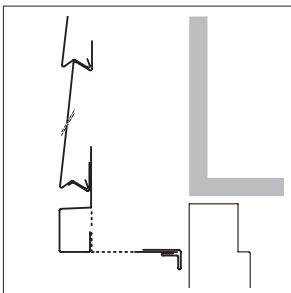

V3.1

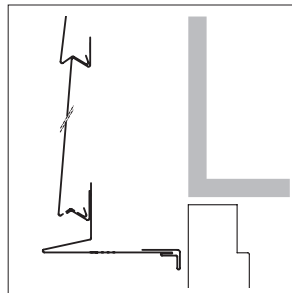

V3.2

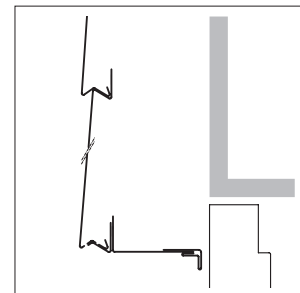

V3.3

Detail V4: Two-part roof edge

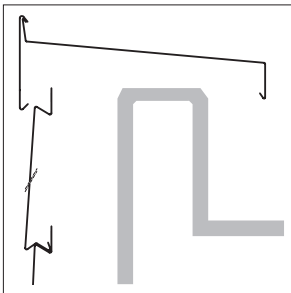

V4.1

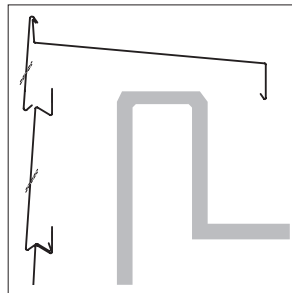

V4.2

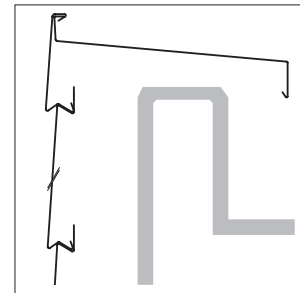

V4.3

SHIPLAP PANEL, DESIGN AND APPLICATION

DESIGN
DETAIL V1, BASE

V1.1

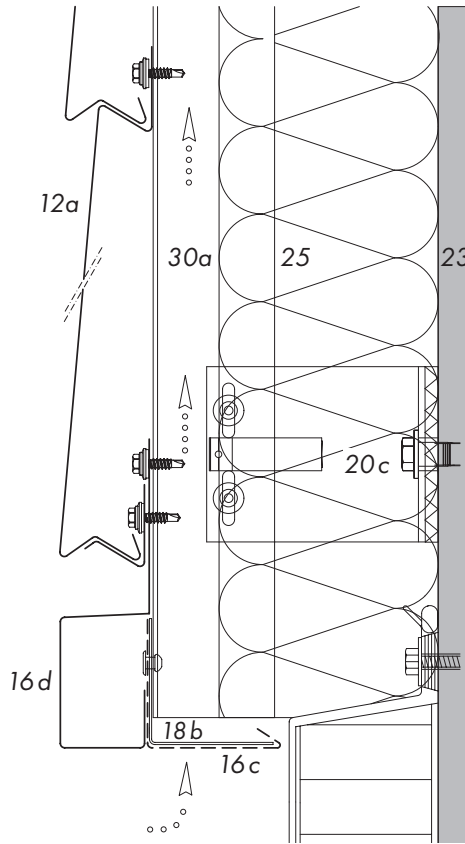

V1.2

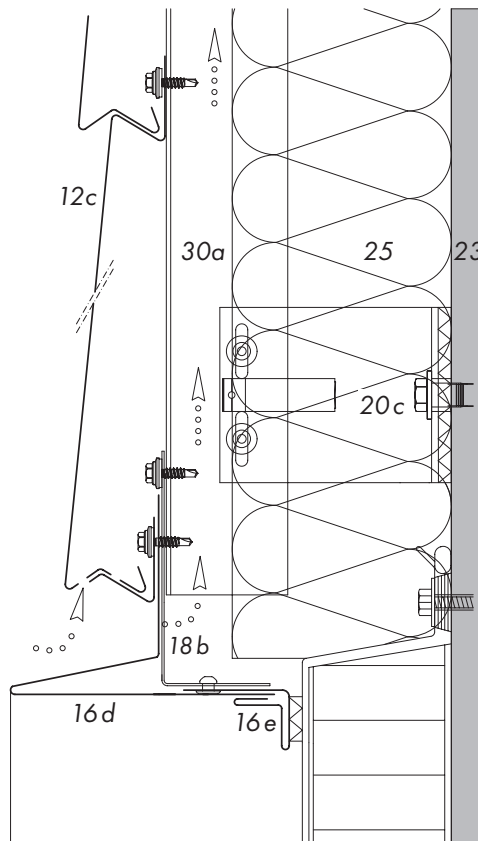

V1.3

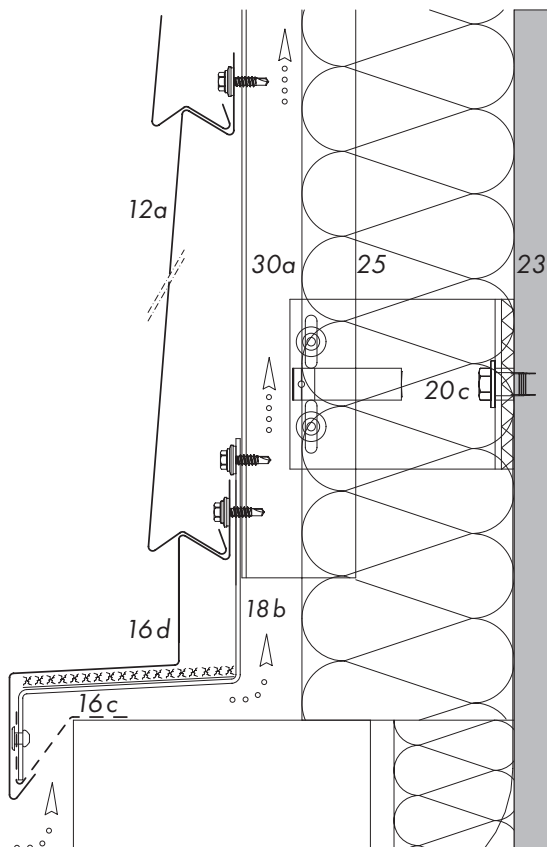
**Detail V1: Base**

- 12 RHEINZINK-Shiplap Panel ST 40
 - a Standard panel
 - c Standard panel, partly perforated
- 16 RHEINZINK-Building Profile
 - c Perforated strip
 - d Base profile
 - e Receiver strip, with sealant tape
- 18 Support Profile
 - b Aluminium
- 19 Separating Layer
 - a Structured underlay VAPOZINC
 - Alternative: glued to support profile over entire surface
- 20 Substructure
 - c Bracket system, with thermal break*
- 23 Supporting Structure
- 25 Thermal Insulation
- 30 Ventilated Air Space
 - a Depth of air space ≥ 20 mm

* Manufacturer's guidelines must be observed.

SHIPLAP PANEL, DESIGN AND APPLICATION

DESIGN

DETAIL V2, WINDOW SILL

V2.1

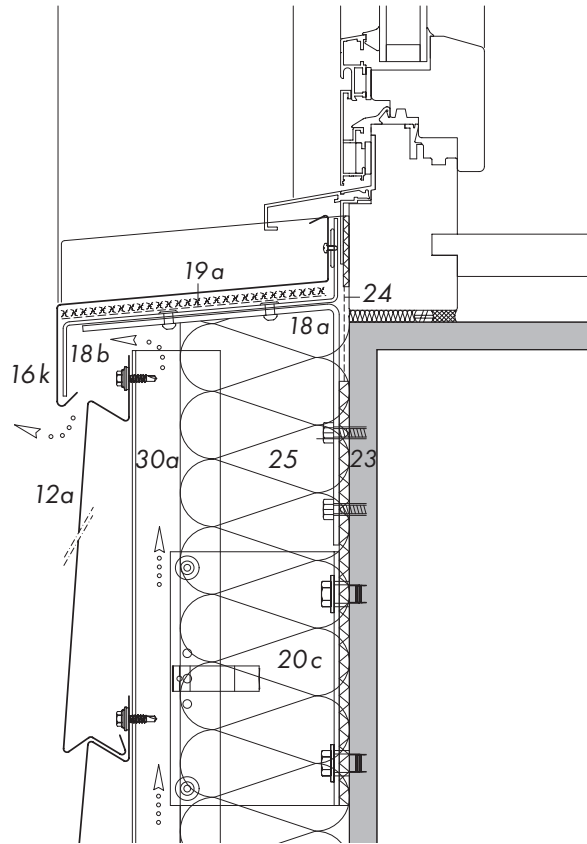

V2.2

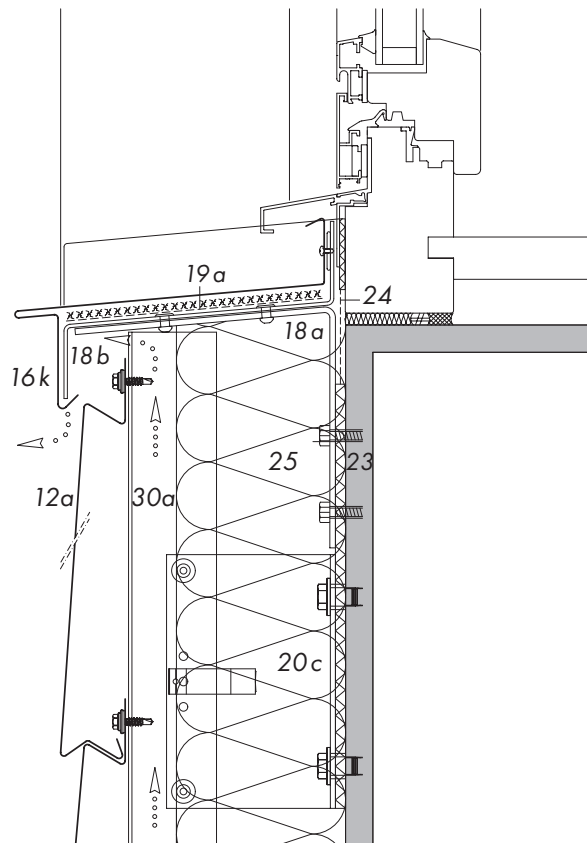

V2.3

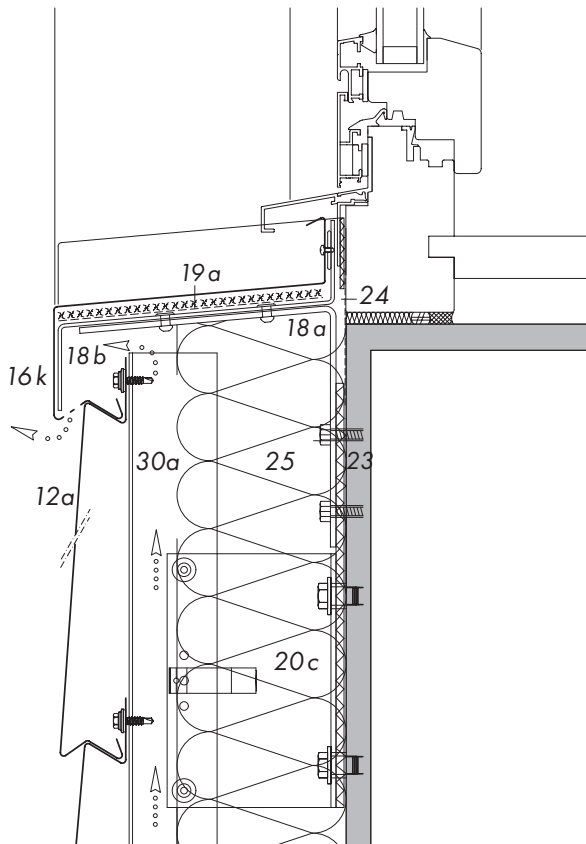
**Detail V2: Window Sill**

- 12 RHEINZINK-Shiplap Panel ST 40
 - a Standard panel
- 16 RHEINZINK-Building Profile
 - k Window sill coping, $\geq 3^\circ$ slope, optional partly perforated
- 18 Support Profile
 - a Galvanised steel support angle with thermal break
 - b Aluminium
- 19 Separating Layer
 - a Structured underlay VAPOZINC
 - Alternative: glued to support profile over entire surface
- 20 Substructure
 - c Bracket system, with thermal break*
- 23 Supporting Structure
- 24 Window Foil
- 25 Thermal Insulation
- 30 Ventilated Air Space
 - a Depth of air space ≥ 20 mm

* Manufacturer's guidelines must be observed.

SHIPLAP PANEL, DESIGN AND APPLICATION

DESIGN

DETAIL V3, WINDOW LINTEL

V3.1

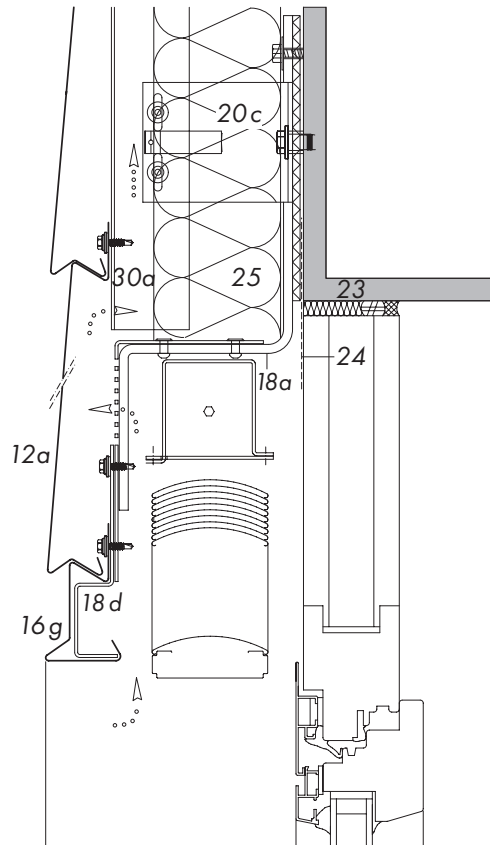

V3.2

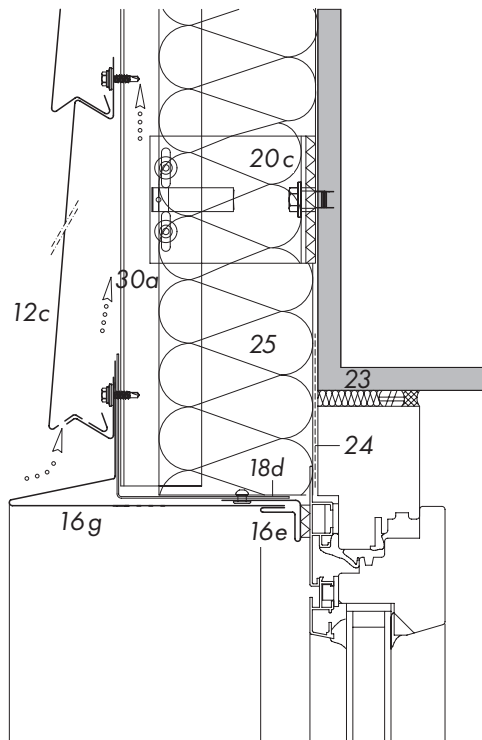

V3.3

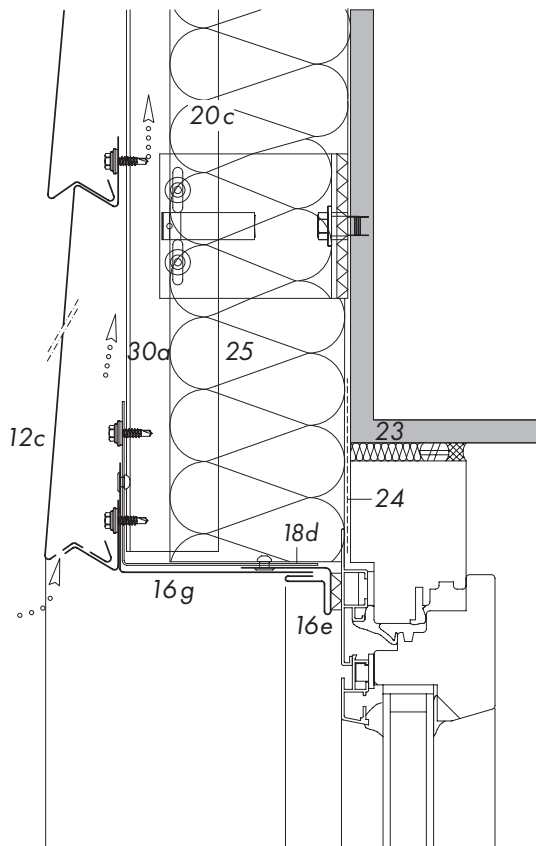
**Detail V3: Window Lintel**

- 12 RHEINZINK-Shiplap Panel ST 40
 - a Standard panel
 - c Standard panel, partly perforated
- 16 RHEINZINK-Building Profile
 - e Receiver strip, with sealant tape
 - g Lintel profile
- 18 Support Profile
 - a Galvanised steel, support profile with thermal break
 - b Aluminium*
- 20 Substructure
 - c Bracket system, with thermal break**
- 23 Supporting Structure
- 24 Window Foil
- 25 Thermal Insulation
- 30 Ventilated Air Space
 - a Depth of air space ≥ 20 mm

* If fire breaks are required use galvanised steel ≥ 1 mm

** Manufacturer's guidelines must be observed.

SHIPLAP PANEL, DESIGN AND APPLICATION

DESIGN

DETAIL V4, TWO-PART ROOF EDGE

V4.1

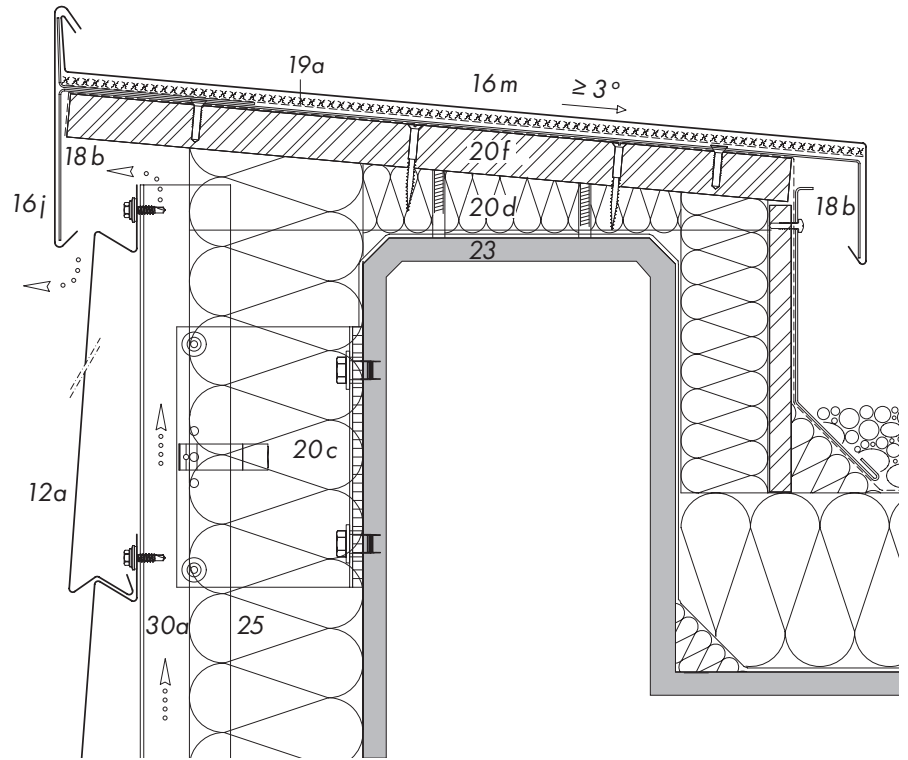

V4.2

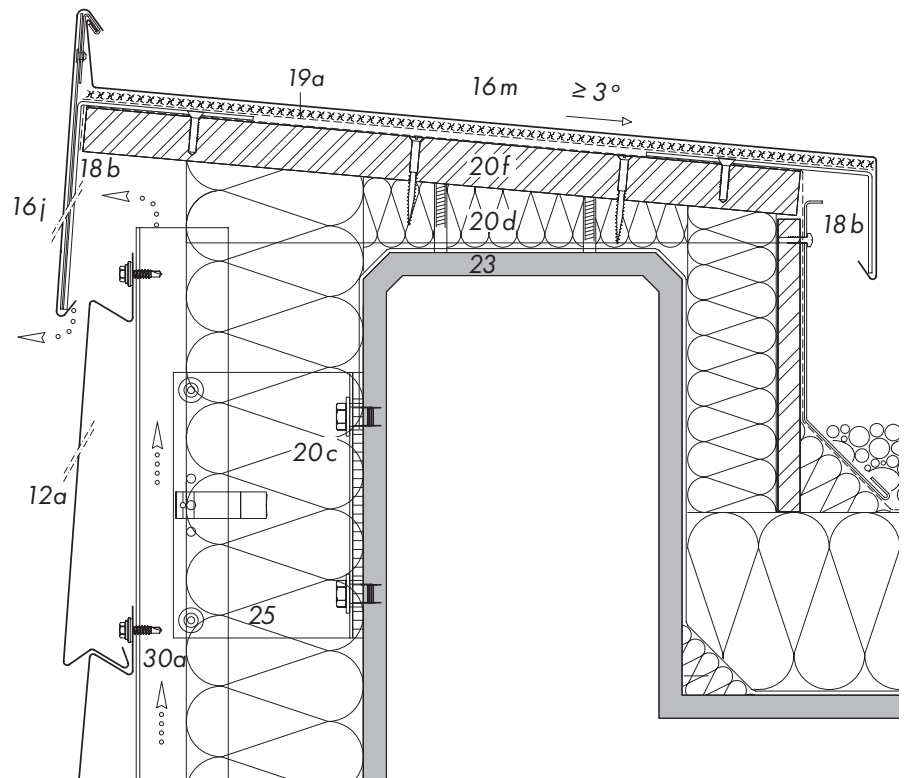

V4.3

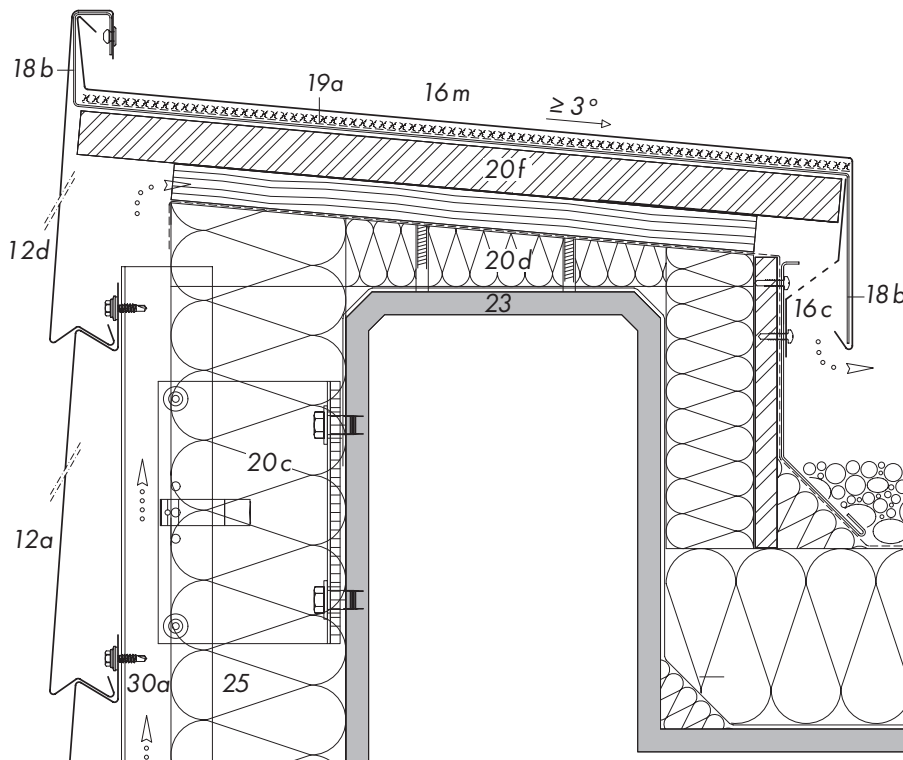
**Detail V4: Two-Part Roof Edge**

- 12 RHEINZINK-Shiplap Panel ST 40
 - a Standard panel
 - d Fitting panel
- 16 RHEINZINK-Building Profile
 - c Perforated strip
 - j Fascia profile
 - m Wall coping
- 18 Support Profile
 - b Aluminium
- 19 Separating Layer
 - a Structured underlay VAPOZINC
 - Alternative: glued to support profile over entire surface
- 20 Substructure
 - c Bracket system, with thermal break*
 - d Wood
 - f OSB/veneer plywood sheathing, thickness min. 22 mm
- 23 Supporting Structure
- 25 Thermal Insulation
- 30 Ventilated Air Space
 - a Depth of air space ≥ 20 mm

* Manufacturer's guidelines must be observed.





REFERENCE PROJECTS



Additional project references
can be found on
the Internet at
www.rheinzink.com



Title: Apotex Centre, Winnipeg, Canada

Architect: Corbett Cibinel Architects, Winnipeg, MB, Canada

RHEINZINK-work done by:

Tri Clad Designs Inc., Lorette, MB, Canada

1. Helene-Künne-Allee, Braunschweig, Germany

Architect: Dipl.-Ing. Germund Gladrow, Braunschweig, Germany

RHEINZINK-work done by:

Dachbaukunst Quedlinburg, Westerhausen, Germany

2. MG AVU, Gallery of Modern Art, Academy of Fine Arts, Prague, Czech Republic

Architect: JIRAN/KOHOUT Architekti s.r.o., Prague, Czech Republic

RHEINZINK-work done by:

PARIO s.r.o., Prague, Czech Republic

3. Grammar School Zitadelle Jülich, Jülich, Germany

Architect: Architekturbüro Schüßler, Jülich, Germany

RHEINZINK-work done by:

ATL Montage Arvid Thorwald Lobada GmbH, Schermbeck, Germany

4. Housing Corporation Duisburg-Hamborn eG, Duisburg, Germany

Architect: STELLARCHITEKTUR, Münster, Germany

RHEINZINK-work done by:

Schaffeld-Bedachungsgesellschaft mbH, Oberhausen, Germany

5. Institute of Experimental Haematology and Transfusion Medicine (IHT), Bonn, Germany

Architect: Architektur und Bauleitung Löchte, Bonn, Germany

RHEINZINK-work done by:

Aude GmbH, Bielefeld, Germany

6. Savings Bank Branch Kirchlengern, Kirchlengern, Germany

Architect: Schlattmeier Planungs GmbH & Co. KG, Herford, Germany

RHEINZINK-work done by:

Aude GmbH, Bielefeld, Germany



RHEINZINK GmbH & Co. KG
Postfach 1452
45705 Datteln
Germany

Tel.: +49 2363 605-0
Fax: +49 2363 605-209

info@rheinzink.de
www.rheinzink.com